

INCH-POUND

MIL-DTL-23659E
27 September 2007
Superseding
MIL-DTL-23659D
3 March 2003

DETAIL SPECIFICATION

INITIATORS, ELECTRIC, GENERAL DESIGN SPECIFICATION FOR

This specification is approved for use by all Departments and Agencies of the
Department of Defense

1. SCOPE.

1.1 Scope. This specification furnishes general requirements for design and establishes uniform methods for testing electric initiators and electric initiator subassemblies. The purpose of the testing program is to determine the electric characteristics, soundness of mechanical design, output, and resistance to deleterious service environments. For purposes of this specification the term electric initiator includes items classified in FSC 1377 such as hot wire initiators, exploding bridgewire initiators, exploding foil initiators, conductive mix initiators, etc. Electric primers are not covered in this specification. All requirements for exploding foil initiators used in safety sensitive non-interrupted explosive train applications are contained in appendix A. Requirements for all other items are in the main body of this document.

The term electric initiator does not include complete assemblies which have electric initiators as subassemblies, but include only the subassemblies themselves. In addition, electric initiators must be safe for handling, transportation, storage and use and must not deteriorate to a degree, which would render their performance or safety doubtful under normal service handling, adverse storage and transportation. RF susceptibility

Comments, suggestions, or questions on this document should be addressed to DEPARTMENT OF THE NAVY, Indian Head Division, NSWC, Code E11G3, Document Control, 4072 North Jackson Road Suite 106, Indian Head, MD 20640-5115 OFFICIAL BUSINESS, or emailed to amanda.penn@navy.mil. Since contact information can change, you may want to verify the currency of this address information using the ASSIST Online database at <http://assist.daps.dla.mil/>.

AMSC N/A

FSC: 1377

DISTRIBUTION STATEMENT A: Approved for public release; distribution is unlimited.

requirements and tests have not been included in this specification. Implicit in the one watt and one ampere maximum no-fire requirements of this specification is the recognition of the hazards of electromagnetic radiation to ordnance (HERO). This one watt and one ampere requirement in conjunction with other design requirements stated herein does not solve the HERO problem; however they do serve as a means of reducing hazards from all spurious electric sources including electromagnetic radiation. General requirements for weapon systems to preclude HERO are established in MIL-STD-464.

1.2 Classification. Initiators covered by this specification are divided into two classes:

Class A – Includes initiators that are capable of being actuated within one second (exclusive of delay element time, if present) from a 28 ± 2 volt source capable of delivering not less than 10 amperes.

Class B – Includes initiators that are not capable of being actuated within one second (exclusive of delay element time, if present) from a 28 ± 2 volt source capable of delivering not less than 10 amperes. All requirements for exploding foil initiators used in fuzes or other safety sensitive applications are contained in Appendix A.

2. APPLICABLE DOCUMENTS.

2.1 General. The documents listed in this section are specified in sections 3, 4, or 5 of this specification. This section does not include documents cited in other sections of this specification or recommended for additional information or as examples. While every effort has been made to ensure the completeness of this list, document users are cautioned that they must meet all specified requirements of documents cited in sections 3, 4, or 5 of this specification, whether or not they are listed.

2.2 Government documents.

2.2.1 Specifications, standards, and handbooks. The following specifications, standards, and handbooks form a part of this document to the extent specified herein. Unless otherwise specified, the issues of these documents are those cited in the solicitation or contract.

DEPARTMENT OF DEFENSE STANDARDS

MIL-STD-202	Electronic and Electric Component Parts
MIL-STD-331	Fuze and Fuze Components, Environmental and Performance Tests For
MIL-STD-464	Electromagnetic Environmental Effects, Requirements for Systems
MIL-STD-810	Environmental Engineering Considerations And Laboratory Tests

(Copies of these documents are available online at <http://assist.daps.dla.mil/> or from the Standardization Documents Order Desk, Building 4D, 700 Robbins Avenue, Philadelphia PA 19111- 5094.)

2.2.2 Other Government documents, drawings, and publications. This section is not applicable to this document.

2.3 Non-Government publications. This section is not applicable to this document.

2.4 Order of precedence. In the event of a conflict between the text of this document and the references cited herein, the text of this document takes precedence. Nothing in this document, however, supersedes applicable laws and regulations unless a specific exemption has been obtained.

3. REQUIREMENTS.

3.1 Approval for Use of Initiators by Service Personnel. Before any initiator or device utilizing an initiator can be used by Service personnel, it must be approved by the cognizant Safety Authority. Approval for Service use will be granted only after it has been demonstrated that the initiator has met all the requirements of this specification and adequate documentation for procurement as Government furnished equipment is completed and the release to production form has been authenticated. Interim approval can be granted prior to availability of documentation provided it has been demonstrated that the initiator has met all the requirements of this specification. Interim approval shall not exceed six months.

3.2 General. The requirements for design given in this section are considered to be the minimum requirements to which electric initiators shall be subjected.

3.3 Design.

3.3.1 General. The initiator shall be of the simplest and most efficient design (consistent with the originally proposed use) for the widest possible variety of applications. It shall be as simple and safe to assemble and install as practicable. All inert and explosive materials shall be referenced by approved Government specifications where possible. Proprietary materials shall not be used unless specifically approved in writing from the cognizant Safety Authority.

3.3.2. Internal Free Volume. The internal free volume shall be minimized consistent with good design practice.

3.3.3. Weight. The weight of all initiators shall be minimized consistent with good design practice.

3.3.4. Inert Materials. Selection of inert materials shall satisfy the environmental, strength, and weight requirements set forth in the specifications for the unit of intended application. Materials which are nutrients for fungi shall not be used unless specifically approved by the cognizant Safety Authority.

3.3.5. Contacts. The design shall include a provision for shorting all contacts to each other. In the case of pins, a shorting cap shall be supplied, and in the case of leads, the ends shall be bared for purpose of twisting together. Once the initiator is assembled, the contacts shall be shorted (with leads folded to avoid open loops) at all times except for tests of functional purposes. Where two or more contacts are present, per initiator, coding shall be provided for purpose of identification.

3.3.6. Sealing. The initiators shall be sealed and shall pass the leakage requirement of 3.3.14, environment requirements of 3.5 and functional requirements of 3.6 specified in 4.1.2.3, 4.6 and 4.7.

3.3.7. Bridge Material. Carbon shall not be used as bridge material unless specifically approved by the cognizant Safety Authority.

3.3.8. Bridge Circuit Insulation and Insulation Barrier. The bridge circuit shall be electrically insulated from the case except in those instances where an insulated bridge initiator is not compatible with the device of intended application. A continuous insulation barrier shall be provided between the case and any explosive, propellant or pyrotechnic material which is in contact with the bridge circuit. The barrier shall be of a material having high electric resistivity and dielectric strength.

3.3.9. Bridge Circuit Resistance, Bridge Circuit Continuity or Dielectric Withstanding Voltage. The initiator shall be designed such that the measurement of bridge circuit resistance, bridge circuit continuity, or application of dielectric withstanding voltage when tested as specified in 4.4.1 and 4.4.2 will not dud, adversely affect, or cause the initiator to fire.

3.3.10. Explosive, Propellant, Delay Composition, or Pyrotechnic Material.

Any explosive, propellant, delay composition, or pyrotechnic material used in an initiator shall be approved by the cognizant Safety Authority.

3.3.11. Marking. Marking, where applicable, shall be non-defaceable (normally stamp or etch) through normal handling and use and shall include designation, lot number, date of manufacture, and manufacturer's identification.

3.3.12. Radiographic Examination. Each initiator shall be subjected to radiographic examination such as X-ray, neutron bombardment, gamma rays etc. as specified in 4.1.2.2. Radiographic plates shall be identified by date, initiator part number, lot number and serial number.

3.3.13. Performance Reliability. The initiators shall meet all performance requirements at a reliability of not less than 99 percent at a confidence level of 95 percent. The method of analysis shall be in accordance with 4.1.4.

3.3.14. Leakage. The initiators shall pass a dry gas leak test. Initiators which exhibit a leak rate in excess of 10^{-5} cc per second of air at a pressure differential of 1 ± 0.1 atmosphere shall be considered defective. The leak test shall be conducted as specified in 4.1.2.3.

3.4 Electrical Characteristics.

3.4.1 Dielectric Withstanding Voltage. Each initiator produced under a contract shall be subjected to a dielectric withstanding voltage of 500 volts DC for 60 seconds. The leakage current shall not exceed 0.1 milliamperes. The test shall be conducted as specified in 4.4.1. Initiators which exhibit a leakage current in excess of that stated above shall be considered defective and discarded.

3.4.2 Bridge Circuit Resistance or Bridge Circuit Continuity.

3.4.2.1 Initiators with or without Bridge Circuit Gap. For each initiator produced under a contract the bridge circuit resistance or bridge circuit continuity (whichever is applicable) of each bridge circuit shall be as specified in 4.4.2.

3.4.2.2 Initiators with conductive mix materials. If conductive mix materials are used, the conductive mix resistance measurement requirement shall be as specified by the cognizant Safety Authority.

3.4.3 Maximum No-Fire and Minimum 50 Millisecond All-Fire stimuli.

3.4.3.1 General. For purposes of specifying maximum no-fire and minimum 50 millisecond all fire stimuli, initiators covered by this specification are divided into two Classes: "Class A" and "Class B".

3.4.3.1.1 Class A. Includes any initiator that is capable of being actuated within one second (exclusive of delay element time, if present) from a 28 ± 2 volt source capable of delivering not less than 10 amperes.

3.4.3.1.2 Class B. Includes any initiator that is not capable of being actuated within one second (exclusive of delay element time, if present) from a 28 ± 2 volt DC source capable of delivering not less than 10 amperes. Requirements for Class B Exploding Foil Initiators used in fuzes or other safety sensitive initiation applications are defined in Appendix A.

3.4.3.2 Maximum No-Fire Stimuli, Class A

3.4.3.2.1 Power-Current. The initiator shall not fire within 5 minutes when subjected to a current of 1 ampere minimum per bridge with an associated power of 1 watt minimum per bridge. The initiator shall meet this requirement at $70^{\circ} \pm 5^{\circ}\text{F}$. and $220^{\circ} \pm 5^{\circ}\text{F}$. The test method shall be as explained in 4.4.3.1.

3.4.3.2.2 Static Discharge. The initiator shall not fire or dud when subjected to the 25000 volt simulated human electrostatic discharge of 4.4.3.2. The initiator shall meet this requirement at $70^{\circ} \pm 5^{\circ}\text{F}$. and a relative humidity of 50 percent or less.

3.4.3.2.3 Stray Voltage. The initiator shall be capable of withstanding the effects of a stray voltage environment without pre-igniting (firing). The initiator shall meet this requirement at $70^{\circ} \pm 5^{\circ}\text{F}$. The test method shall be as described in 4.4.3.3.

3.4.3.3 Minimum 50 Milliseconds All-Fire Stimulus, Class A. The minimum 50 millisecond all-fire stimulus as defined in 6.3.7 shall be measured as described in 4.4.4. The initiator shall meet this requirement at $70^{\circ} \pm 5^{\circ}\text{F}$., $-80^{\circ} \pm 5^{\circ}\text{F}$., and $225^{\circ} \pm 5^{\circ}\text{F}$.

3.4.3.4 Maximum No-Fire Stimuli, Class B.

3.4.3.4.1 Parameter(s). The maximum no-fire stimulus as defined in paragraph 6.3.9 shall be determined as specified in para 4.4.5.1.

3.4.3.4.2 Static Discharge. The initiator shall not fire or dud when subjected to the 25000 volt simulated human electrostatic discharge of 4.4.3.2. The initiator shall meet this requirement at $70^{\circ} \pm 5^{\circ}\text{F}$ and a relative humidity of 50 per cent or less.

3.4.3.5 Minimum 50 Millisecond All-Fire Stimuli, Class B. The requirements for the minimum 50-millisecond all-fire stimulus as defined in 6.3.7 shall be as specified in 4.4.6.

3.4.4 Bridge Circuit Resistance Subsequent to Actuation Class A and B. If there is a requirement that a fired initiator shall have a minimum open circuit resistance after firing, then the cognizant Safety Authority shall specify the open circuit resistance requirement and the method of test shall be that given in 4.5.

3.5 Environmental.

3.5.1 Forty Foot Drop. To ensure fail-safe capability, the initiator shall not fire when dropped from a height of 40 feet as specified in 4.6.1 and shall be safe for handling and disposal.

3.5.2 Six Foot Drop. The initiator shall not fire when dropped from a height of 6 Feet as specified in 4.6.2. After being subjected to the drop test, the initiators shall meet the design performance requirements when test fired.

3.5.3 Shock. The initiator shall be capable of withstanding shock conditions as specified in 4.6.3. After being subject to the shock test, the initiator shall meet the design performance requirements when test fired.

3.5.4 Vibration. The initiator shall be capable of withstanding vibration conditions as specified in 4.6.4. After being subject to the vibration test, the initiator shall meet the design performance requirements when test fired.

3.5.5 Temperature-Shock/Humidity/Altitude. The initiator shall be capable of withstanding temperature-shock/humidity/altitude cycling conditions as specified in 4.6.5 and shall meet the design performance requirements when test fired.

3.5.6 Cook-Off. The maximum temperature to which an initiator can be exposed for a period of one hour without cookoff shall be established (within 25° F). Test method shall be as specified in 4.6.6.1.

3.5.7 High Temperature Exposure. The maximum temperature (within 25°F) to which an initiator may be exposed for 12 hours and perform satisfactorily at 225°F shall be determined. Test method shall be as specified in 4.6.6.2.

3.5.8 Salt Fog. The initiator shall meet the salt fog test as specified in 4.6.7. After being subject to the salt fog test, the initiator shall meet the design performance requirements when test fired.

3.6 Functional (All Fire Stimulus). The initiator shall meet the all fire stimulus requirements of 3.4.3.3 and 3.4.3.5 at $-80^{\circ} \pm 5^{\circ}\text{F}$., $+70^{\circ} \pm 5^{\circ}\text{F}$., and $+225^{\circ} \pm 5^{\circ}\text{F}$.

3.7 Damage and Deterioration. Damage to or deterioration of any internal or external part of the initiator which could in any manner prevent it from meeting any requirement of this specification shall provide reason to consider the initiator as having failed to meet the test to which it was subjected. Initiators from the 40-foot drop test shall not be subject to this requirement.

3.8 Special requirements. Those special requirements which are in conflict with the requirements of this specification shall be resolved in favor of the special requirements only if necessary for satisfactory operation of the initiator in the unit of proposed use and subject to approval by the Safety Authority. It is recognized that the maximum no-fire requirements of section 3.4.3 cannot be imposed on all weapons systems because of limited power supplies or dimensional requirements which limit the ability of the initiator to dissipate one watt for 5 minutes. Where the maximum no-fire requirements of 3.4.3 are irreconcilable with the available power supply or dimensional requirements, the contractor shall come as close as possible to the requirements stated herein, compatible with the weapons system, and must get written authority from the Safety Authority to deviate from these requirements.

4. VERIFICATION

4.1 Inspection.

4.1.1 Materials. Inspection and testing of component parts and assemblies shall be made to determine compliance with 3.3. Where defects, incompatibility or inferior quality is evident and the Safety Authority deems a material analysis, the contractor will be required to submit samples or specimens to the contracting officer for analysis and approval.

4.1.2 Examination of Product. Examination of all products shall be made to determine if the initiator meets the requirements with respect to workmanship, marking, conformance to drawings, and for any visible defects.

4.1.2.1 Dimensional Inspection. Each part of a new initiator shall be 100 percent dimensionally inspected for conformance to the applicable drawing. Should replacement of a part in the initiator be necessary, the replacement part shall be 100 percent dimensionally, inspected for conformance to the applicable drawing.

4.1.2.2 Radiographic Inspection. All initiators shall be inspected by radiographic means as specified in 3.3.12 and plates examined for defects.

4.1.2.3 Leakage. A leak test shall be conducted with a dry gas leak detector of sufficient sensitivity to ascertain if initiators meet the leak rate requirement of 3.3.14.

4.1.3 Instrumentation. Any suitable instrumentation system may be used e.g. oscillograph, oscilloscope, digital readout, magnetic tape; transducers used with this system may be any state of the art type e.g. piezoelectric, strain gage, variable reluctance, capacitive, potentiometer, etc. However, a five percent system accuracy which includes such factors as non-linearity, frequency response, temperature effects and resolution etc. shall be required. Documented calibration records on the system as a whole or individual components shall be maintained and available for reference.

4.1.4 Safety and Functional Reliability. The number of initiators required to meet the reliability and confidence level of this specification for go-no-go testing is 298. The Safety Authority has the prerogative of specifying the test procedures and methods of statistical analysis which will be used to determine the minimum 50 millisecond all-fire stimuli or the Safety Authority may accept a procedure proposed by the testing laboratory. Para 6.4 summarizes some of the problems in applying various statistical type analyses.

4.2 Test Conditions. The test conditions are described under the individual tests to which they apply. Initiators shall be fired in the temperature conditioning cabinet at the applicable test temperature. If it is not possible to fire in the temperature conditioning cabinet, the initiator shall be fired as quickly as possible after removal from the cabinet and in no case shall the elapsed time exceed five minutes. During the performance of the tests of 4.4.1 through 4.4.6 the possibility of an initiator firing exists; therefore safety procedures equivalent to those taken during the destructive tests shall be followed. All functional tests of initiators are to be performed with the equipment mounted and loaded in a manner to simulate as closely as possible service conditions.

4.3 Engineering Design Tests. The engineering design tests are conducted to determine the technical characteristics as indicated by the initiator design. Determination includes the measurements of the inherent structural, electrical, or other physical and chemical properties, and may utilize data obtained from previous tests. These tests are characterized by controlled conditions and the elimination of human error in judgment, as much as possible, through the use of environmental chambers, measurement techniques, and statistical analysis.

These tests include all the tests in Table I, an explanation of which is given in paragraph 4.3.1. The engineering design test shall be conducted at a Government laboratory or, if by a contractor, shall be witnessed and the test procedures approved by Government personnel as assigned by the Safety Authority.

4.3.1 Explanation of Table I. The following is an explanation of the working procedure to be utilized when working with Table I.

a. A total of 416 initiators are to be tested and all are ultimately destroyed in the minimum 50 millisecond all-fire test, or the cook-off test, or the 40 foot drop test. Reading from left to right along the top row, the 416 initiators are divided into 21 groups consisting of 50, 6, 6, 20, 20 etc. For example:

b. The first group consists of 50 initiators. Reading down the first column it is seen from the "X" designations that this group of 50 initiators is to be subject to the following tests in the sequence given:

Dielectric withstanding voltage
Radiographic
Leakage
Resistance
Static Discharge.
Resistance
Stray Voltage
Resistance
Power current or Stimulus 70°F

and finally destroyed in the Minimum 50 millisecond all fire test at 70°F. Note that some tests, such as resistance are repeated.

c. The second group consists of 6 initiators. Reading down, it is seen from the "X" designations that this group of 6 initiators is to be subject to the following tests in the sequence given:

Dielectric Withstanding Voltage
Radiographic
Leakage
Resistance

TABLE I. ENGINEERING DESIGN TEST SCHEDULE

TEST	REF. PARA	NUMBER OF INITIATORS (GROUPS)																		TOTAL				
		50	6	6	20	20	20	20	20	20	20	20	20	2	2	2	2	2	2		2	2	176	
Dielectric withstanding Voltage	4.4.1	X	X	X	X	X	X	X	X	X	X	X	X	X	X	X	X	X	X	X	X	X	X	416
Radiographic Inspection	4.1.2.2	X	X	X	X	X	X	X	X	X	X	X	X	X	X	X	X	X	X	X	X	X	X	416
Leakage	4.1.2.3	X	X	X	X	X	X	X	X	X	X	X	X	X	X	X	X	X	X	X	X	X	X	416
Bridge Circuit Resistance	4.4.2	X	X	X	X	X	X	X	X	X	X	X	X	X	X	X	X	X	X	X	X	X	X	416
Static Discharge	4.4.3.2	X																						50
Bridge Circuit Resistance	4.4.2	X																						50
Stray Voltage	4.4.3.3	X																						50
Bridge Circuit Resistance	4.4.2	X																						50
Power Current or Stimulus 70° F	4.4.3.1 4.4.5.1	X																						50
Resistance	4.4.2	X																						50
Forty FootDrop	4.6.1		X																					6
Six Foot Drop	4.6.2			X																				6
Shock	4.6.3				X								X	X	X	X	X	X	X	X	X	X	X	38
Vibration	4.6.4					X							X	X	X	X	X	X	X	X	X	X	X	38
Temperature-Shock/Humidity/Altitude	4.6.5						X																	20
Cook-Off	4.6.6.1							X																20
High Temperature Exposure	4.6.6.2								X															20
Salt Fog Test	4.6.7									X														20
Radiographic Inspection	4.1.2.2			X	X	X	X						X	X	X	X	X	X	X	X	X	X	X	84
Bridge Circuit Resistance	4.4.2			X	X	X	X		X	X			X	X	X	X	X	X	X	X	X	X	X	124
Leakage	4.1.2.3			X	X	X	X						X	X	X	X	X	X	X	X	X	X	X	84
Static Discharge	4.4.3.2			X	X	X	X		X	X			X	X	X	X	X	X	X	X	X	X	X	124
Bridge Circuit Resistance	4.4.2			X	X	X	X		X	X			X	X	X	X	X	X	X	X	X	X	X	124
Power Current or Stimulus 70° F	4.4.3.1 or 4.4.5.1			X	X	X	X			X			X	X	X	X	X	X	X	X	X	X	X	104
Power Current or Parameters 225° F	4.4.3.1 or 4.4.5.1								X		X													40
Bridge Circuit Resistance	4.4.2			X	X	X	X		X	X	X		X	X	X	X	X	X	X	X	X	X	X	144
Min. 50 Milli sec. All-Fire 70° F	4.4.4	X		X	X	X				X			X			X			X				X	298
Min. 50 Milli sec. All-Fire -80° F	4.4.6						X					X		X			X				X			46
Min. 50 Milli sec. All-Fire 225	4.7								X		X			X			X			X			X	46

and finally destroyed in the 40 foot Drop. Similar reasoning applies to each of the 21 groups.

d. The total in the right hand column is the number of initiators subject to that particular test in its respective row. For example, adding up 20, 20, 2, 2, and 2 yields a total of 46 initiators subject to the 50 millisecond all-fire test at -80°F.

4.3.2 Rejection and Retest (Engineering Design Tests). Failure of any initiator to conform to the applicable requirements of this specification shall be cause for rejection of the design of the initiator. However, if it can be determined that the initiator failed to meet the requirements as a result of previous firing of the initiator, the failure and reason for failure shall be noted and the firing repeated using another initiator. If the failure can be attributed to design or other defect, the initiators to be used in engineering design testing may be reworked, have parts replaced or redesigned to correct the defects, and all the tests shall be repeated. Before the tests are repeated, full particulars concerning the failure and action taken to correct the defects shall be submitted to the cognizant Safety Authority.

4.3.3 Final Design Configuration and Same Production Run. Only initiators of final design configuration and from the same production run shall be subjected to engineering design testing.

4.4 Test Methods.

4.4.1 Dielectric Withstanding Voltage. To determine if the initiator meets the dielectric withstanding voltage requirements of 3.3.9 and 3.4.1, a dielectric withstanding voltage of 500 ± 25 volts d.c. shall be applied for 60 seconds between pairs of pins or leads in all combinations prior to assembly of the bridge and between the shorted pins or leads (all pins or leads shorted to each other external to the initiator) and the case after complete assembly of the initiator. In each test, the leakage current shall be measured with an accuracy of 5 percent. These tests shall be conducted in accordance with MIL-STD-202 Method 301.

4.4.2 Bridge Circuit Resistance or Bridge Circuit Continuity. To determine if the initiator meets the requirements of 3.3.9 and 3.4.2.1, the test method shall be as follows: For an initiator which does not contain a bridge circuit gap the resistance of each bridge circuit shall be measured with an accuracy of one percent using a test which subjects the bridge circuit to a current of less than 50 milliamperes. These tests shall be conducted in accordance with MIL-STD-202, Method 303 except that the measurement shall be made at or corrected to 70°F. For an initiator which does contain a bridge circuit gap as defined in 6.3.5 the bridge circuit continuity, excluding the gap, shall be determined using a test circuit which subjects the bridge circuit to a current of less than 50 milliamperes.

4.4.3 Maximum No-Fire Stimuli, Class A

4.4.3.1 Power Current. To determine if the initiator meets the power current stimulus of 3.4.3.2.1, a direct current of not less than one ampere supplying a minimum of one watt shall be applied to the bridge circuit for a period of at least five minutes. For an initiator having more

than one bridge, the current shall be applied to all bridge circuits simultaneously. The test current shall be regulated throughout the period of application to within 2 percent. If a rectified current is used, the ripple content shall not exceed 5 percent rms of the test current. The initiator shall be conditioned at $70 \pm 5^\circ\text{F}$ or $225 \pm 5^\circ\text{F}$, as appropriate (see Table I) for a period of 12 hours.

4.4.3.2 Static Discharge. To determine if the initiator meets the requirements of 3.4.3.2.2 or 3.4.3.4.2, a 500 ± 5 percent picofarad capacitor charged to 25000 ± 500 volts and 5000 ± 5 percent and 500 ± 5 percent ohm resistor shall be connected in a 5 microhenry total inductance series circuit between pairs of pins or leads in all combinations and between the shorted pins or leads (all pins or leads shorted to each other external to the initiator) and the case of the initiator. The series connection shall be maintained for 60 seconds. All of the initiators shall be tested using the 5000 ± 5 percent ohm resistor, and then using the 500 ± 5 percent ohm resistor. Switching in this circuit shall be accomplished by bringing together two 0.5 ± 0.05 inch spherical metal electrodes from an initial separation of 3 inches in air. Each series test shall constitute a separate test. Initiators used for this test shall be temperature conditioned for a minimum time of 12 hours at $70^\circ \pm 5^\circ\text{F}$.

4.4.3.3 Stray Voltage. To determine if the initiator meets the requirements of 3.4.3.2.3, each initiator shall be subjected to 2000 pulses of direct current. Each pulse shall be of 300 milliseconds duration and pulse rate shall be 2 per second. Each pulse shall have a minimum amplitude of 100 ± 5 milliamperes. The initiator shall be temperature conditioned at $70^\circ \pm 5^\circ\text{F}$ for a period of 12 hours.

4.4.4 Minimum 50 Millisecond All-Fire Stimulus, Class A. To determine if the initiator meets the minimum 50 millisecond all-fire stimulus requirement of 3.4.3.3, a direct current pulse of not more than 5 amperes shall be applied to the bridge circuit. For an initiator having more than one bridge, the current pulse shall be applied to one bridge circuit only. The test current shall be a d.c. current pulse, regulated throughout the period of application, to within 2 percent of the desired value. If a rectified current is used, the ripple content shall not exceed 5 percent rms of the test current. The initiators shall be preconditioned at $70 \pm 5^\circ\text{F}$, $-80^\circ \pm 5^\circ\text{F}$, or at $225^\circ \pm 5^\circ\text{F}$, as appropriate, (see Table I) for a period of 12 hours.

4.4.5 Maximum No-Fire Stimuli Class B

4.4.5.1. Power Current. To determine the maximum no-fire stimulus as required by 3.4.3.4.1, the bridge circuit shall be pulsed with current from the power supply (firing unit) of the unit of intended application or with a current which simulates that current. One parameter of the firing circuit, e.g. voltage, current, capacitance, etc., shall be chosen and shall be varied according to the requirements of the statistical test used. In each case, the parameter varied shall be adjusted to within 2 percent of the required value. For initiators having more than one bridge, only one bridge circuit shall be pulsed with current. Initiators used for this test shall be temperature conditioned for a minimum time of 12 hours at $+70 \pm 5^\circ\text{F}$.

4.4.5.2 Static Discharge. To determine if the initiator meets the requirements of 3.4.3.4.2, a 500 ± 5 percent picofarad capacitor charged to 25000 ± 500 volts and 5000 ± 5 percent and 500 ± 5 percent ohm resistor shall be connected in a 5 microhenry total inductance

series circuit between pairs of pins or leads in all combinations and between the shorted pins or leads (all pins or leads shorted to each other external to the initiator) and the case of the initiator. The series connection shall be maintained for 60 seconds. All of the initiators shall be tested using the 5000 ± 5 percent ohm resistor, and then using the 500 ± 5 percent ohm resistor. Switching in this circuit shall be accomplished by bringing together two 0.5 ± 0.05 inch spherical metal electrodes from an initial separation of 3 inches in air. Each series test shall constitute a separate test. Initiators used for this test shall be temperature conditioned for a minimum time of 12 hours at $70^\circ \pm 5^\circ\text{F}$.

4.4.6 Minimum 50 Millisecond All-Fire Stimulus, Class B. To determine the minimum 50 millisecond all-fire stimulus as required by 3.4.3.5, the bridge circuit shall be energized from the power supply (firing unit) of the unit of intended application or from a source which simulates that supply. One parameter of the firing circuit e.g. voltage, current, capacitance, etc. shall be chosen and shall be varied according to the requirements of the statistical test used. In each case, the parameter varied shall be adjusted to within 2 percent of the required value. For initiators having more than one bridge, only one bridge circuit shall be energized. Initiators used for this test shall be temperature conditioned for a minimum time of 12 hours at $-80^\circ \pm 5^\circ\text{F}$.

4.5 Bridge Circuit Resistance Subsequent to Actuation, Class A and B. To determine if the initiator meets the requirement of 3.4.4, when applicable, all initiators which will be tested according to the minimum 50 millisecond all-fire tests specified in 4.4.4 or 4.4.6 shall be subjected to the following test: The bridge circuit resistance of each bridge circuit shall be measured in accordance with MIL STD 202, Method 302 using test condition B ($500 \text{ volt} \pm 10$ per cent). This test shall be conducted within a period of 5 minutes subsequent to actuation of the initiator.

4.6 Environmental Tests.

4.6.1 Forty Foot Drop. To determine if the initiators meet the requirement of 3.5.1, the forty foot drop test shall be conducted in accordance with test method A3 of MIL STD 331 except as modified herein. Six unprotected initiators are to be dropped and impacted in each of the following orientations:

2 unprotected initiators nose up

2 unprotected initiators nose down

2 unprotected initiators horizontal

4.6.2. Six Foot Drop. To determine if the initiators meet the requirements of 3.5.2, six unprotected initiators are to be dropped and impacted onto a 2 inch thick steel plate imbedded in concrete, in each of the following orientations where possible:

2 unprotected initiators nose up

2 unprotected initiators nose down

2 unprotected initiators horizontal

4.6.3 Shock. To determine if the initiators meet the shock requirement of 3.5.3, the initiators shall be tested as follows. Initiators are to be mounted in the device of intended use or in a suitable test vehicle.

If the test is conducted using a suitable test vehicle, the degree of support shall be the same as that afforded by the device of intended application. The shock pulse shall be applied to the initiator's mounting points in both directions along each of three mutually perpendicular axes. The shape of each shock pulse shall approximate as nearly as possible a half sine wave. The amplitude of each shock pulse shall exceed 200 g's for 1.5 ± 0.4 milliseconds and it shall exceed 65 g's for 9 ± 0.9 milliseconds. Initiators shall be free from visible damage or leaks (if applicable), and shall perform satisfactorily in function tests subsequent to this test.

4.6.4 Vibration. To determine if the initiators meet the requirements of 3.5.4, they shall be vibration tested per Method 514 of MIL-STD-810. If there is not adequate data to select the method, procedure, test levels, or test duration; the following test may be used: Initiators shall be mounted in a suitable test fixture. A resonance survey shall be conducted in each of three mutually perpendicular axes and the resonance points noted. A vibration dwell using a 2 g input shall be conducted for 30 minutes at each of the 4 most severe resonance points. The dwell shall be peaked in case the resonant point shifts. After resonant dwell the initiators shall be vibration cycled for the time shown in Table II. The vibration cycling shall be sinusoidal vibration to the levels shown in Figure 1. The frequency shall be logarithmically swept from 5 Hz to 2000 Hz and return to 5 Hz in 20 minutes.

Table II. Vibration Test Schedule/Axis.

Resonances	0	1	2	3	4
Total Dwell Time (minutes)	0	30	60	90	120
Total Cycling Time (minutes)	180	150	120	90	60

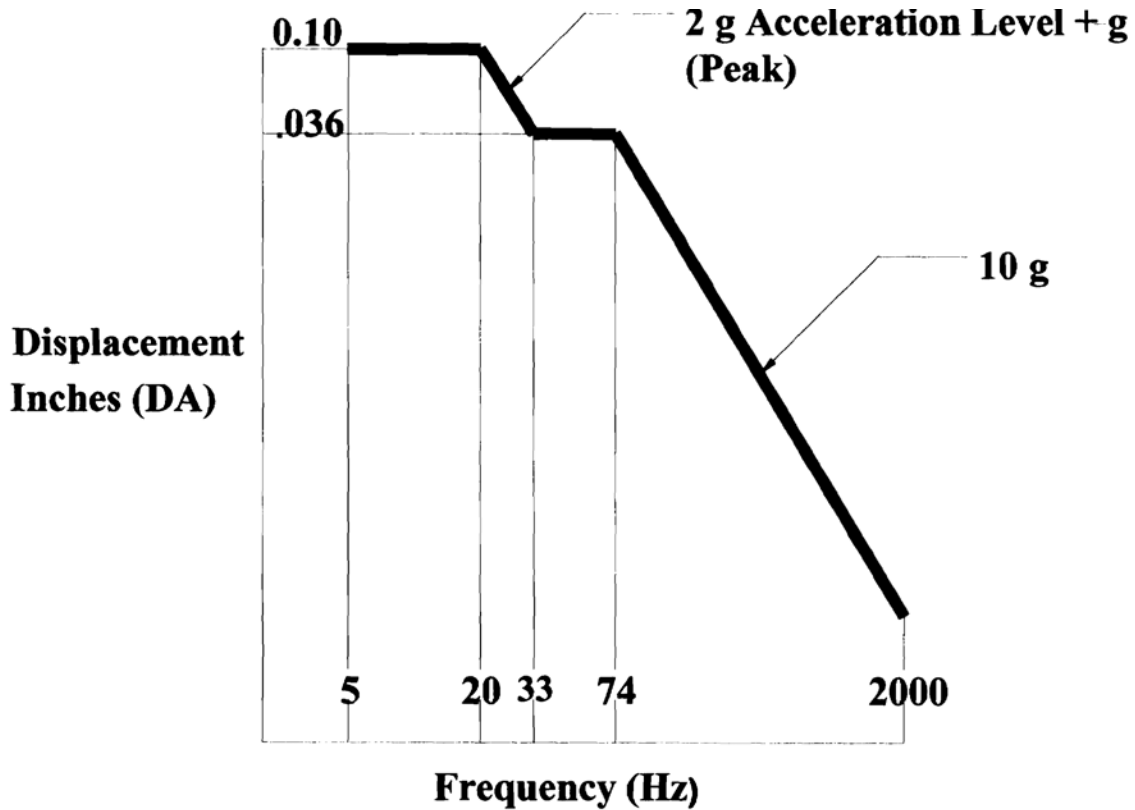

Figure 1 Vibration Test Levels

Vibration testing shall be conducted at -65 °F, 70 °F, and 200 °F. Initiators shall be vibrated for 180 minutes in each of three mutually perpendicular axes at each temperature.

4.6.5 Temperature-Shock/Humidity/Altitude. To determine if the initiators meet the requirements of 3.5.5, the initiators shall be subjected to the temperature-shock/humidity/altitude test as outlined below.

a. The schedule has been arranged in such a manner that operations are not required outside normal working hours except for such supervision as may be necessary to insure proper operation of the test equipment.

b. It is not mandatory that the day/clock time schedule given below be followed; however, it is mandatory that the time, environmental, and sequence requirements be adhered to. It is also noted that only two conditioning chambers are required to accomplish this test. No less than two chambers may be used and still accomplish the temperature shock portion of this test. If it is desired to use three chambers, it is permissible provided the time, environmental, and sequence requirements are met. The fluctuations from the specified temperatures shall not exceed 5°F. When the temperature/altitude chamber door is opened to place test items inside, the chamber pressure will become atmospheric. The time required to return the chamber pressure to 0.65 pounds per square inch (psi) shall not exceed 1 hour.

c. Test specimens shall be supported on screen trays or racks so that all areas are exposed to the prescribed atmospheric conditions at all times throughout the test.

Procedure

- Monday 0800 - Place test items in a chamber maintained at +70°F at 50 percent relative humidity (RH).
- 1200 - Raise chamber temperature to + 160°F and the RH to 95 percent. The chamber temperature shall reach + 160°F at 95 percent RH not later than 1300.
- 1600 - Remove test items from above chamber and immediately place in a chamber maintained at - 65°F at a pressure altitude of 70,000 feet. (0.65 psi)
- Tuesday 0800 - Remove test items from above chamber and immediately place in a chamber maintained at + 70°F at 50 percent RH.
- 1200 - Remove test items from above chamber and immediately place in a chamber maintained at - 65°F at a pressure altitude of 70,000 feet. (0.65 psi)
- 1600 - Remove test items from above chamber and immediately place in a chamber maintained at + 160°F at 95 percent RH.
- Wednesday 0800 - Reduce chamber temperature to + 70°F at 50 percent RH. The chamber temperature shall reach + 70°F at 50 percent RH not later than 0900.
- 1200 - Raise chamber temperature to + 160°F at 95 percent RH. The chamber temperature shall reach + 160°F at 95 percent RH not later than 1300.
- 1600 - Remove test items from above chamber and immediately place in a chamber maintained at - 65°F at a pressure altitude of 70,000 feet. (0.65 psi)
- Thursday 0800 - Remove test items from above chamber and immediately place in a chamber maintained at + 70°F at 50 percent RH.

1200 - Remove test items from above chamber and immediately place in a chamber maintained at - 65°F at a pressure altitude of 70,000 feet. (0.65 psi)

600 - Remove test items from above chamber and immediately place in a chamber maintained at + 160°F at 95 percent RH.

Friday 0800 - Reduce chamber temperature to + 70°F at 50 percent RH. The chamber temperature shall reach + 70°F at 50 percent RH not later than 0900.

1200 - Raise chamber temperature to + 160°F at 95 percent RH. The chamber temperature shall reach + 160°F at 95 percent RH not later than 1300.

1600 - Remove the items from above chamber and immediately place in a chamber maintained at - 65°F at standard ambient pressure.

d. This schedule shall be followed for a total of 4 weeks (28 days) except that on the second and fourth weekends the soak time shall be from 1200 on Friday until 0800 on Monday at a temperature of + 160°F at 95 percent RH. At the conclusion of the temperature-shock/humidity/altitude test, the test items shall be allocated to the tests specified in Table I.

4.6.6 Cook-Off and High Temperature Exposure

4.6.6.1 Cook-Off. Four initiators shall be placed in an oven preheated to the highest temperature which it is estimated that the initiators will withstand for 1 hour. If no initiator cooks off during 1 hour, the temperature shall be increased 25°F. and the test repeated with four new initiators. The test shall be repeated in 25° increments until cook-off of at least one initiator occurs within a 1 hour period. If cook-off occurs in the first group tested, the temperature shall be decreased 25°F. and the test repeated with four new initiators. The test shall be repeated in 25° decrements until cook-off does not occur within a 1 hour period. The purpose of this test is explained in the requirements in 3.5.6.

4.6.6.2 High temperature exposure. To determine if the initiators meet the requirements of high temperature exposure of 3.5.7, 10 initiators shall be placed in an oven preheated to a temperature 25°F. less than the maximum determined for exposure without cook-off in 4.6.6.1. The temperature shall be maintained for 12 hours. If no initiator cooks off, the 10 initiators shall be cooled to 70°F and functionally tested. If any initiator cooks off, or fails to meet design performance requirements after cooling, the test shall be repeated with additional groups of initiators, decreasing the temperature in increments of 25°F until design performance requirements are met.

4.6.7 Salt Fog Test. To determine if the initiators meet the requirements of 3.5.8, the salt fog test shall be conducted according to Method 509.4 Procedure 1 of MIL-STD-810.

4.7 Functional Test. The initiators, and where practicable, their firing test devices, shall be temperature conditioned and maintained at the required temperature for at least 1 hour after the temperature of all parts has been stabilized; then the initiators shall be test fired. A simulated test device and initiator with a temperature sensitive element shall be used as a grain temperature monitor during temperature conditioning. Functions shall comply with the requirements of 3.6. If the initiator cannot be test fired within the temperature chamber, the test devices shall be fired within 5 minutes after removal from the chamber. Whenever it is necessary to repeat low (-80°F) temperature conditioning of a cold device, all condensation shall be removed from the device before it is returned to the temperature conditioning chamber.

5. PACKAGING.

5.1 Packaging. For acquisition purposes, the packaging requirements shall be as specified in the contract or order (see 6.2). When packaging of materiel is to be performed by DoD or in-house contractor personnel, these personnel need to contact the responsible packaging activity to ascertain packaging requirements. Packaging requirements are maintained by the Inventory Control Point's packaging activities within the Military Service or Defense Agency, or within the military service's system commands. Packaging data retrieval is available from the managing Military Department's or Defense Agency's automated packaging files, CD-ROM products, or by contacting the responsible packaging activity.

6. NOTES.

(This section contains information of a general or explanatory nature that may be helpful, but is not mandatory.)

6.1 Intended Use. This specification is intended to prescribe practices to be followed in the design of electrical initiators and prescribes test procedures for the evaluation of the initiators by subjecting them to simulated and accelerated environmental conditions and to functional tests as necessary to insure satisfactory electrical and functional performance and reliability when initiators are utilized or stored under the range of conditions encountered in service. The initiators covered by this specification are designed specifically for military use, and have no commercial applications.

6.2 Acquisition requirements. Acquisition documents should specify the following:

- a. Title, number, and date of the specification.
- b. Issue of DoDISS to be cited in the solicitation, and if required, the specific issue of individual documents referenced.
- c. Packaging requirements (see 5.1).

6.3 Definitions. For purposes of this specification the following are definitions of items or terms pertaining to electric initiators.

6.3.1 Initiator. Any single discrete unit, device or subassembly whose actuation is caused by the application of electric energy which in turn initiates an explosive, propellant, or pyrotechnic material contained therein. The term "initiator" does not include complete assemblies which have electric initiators as subassemblies but includes only the subassemblies themselves. The following are definitions of typical examples of electric initiators.

6.3.1.1 Hot Wire Initiator. Any initiator whose bridgewire is heated by the direct application of electric energy to effect initiation.

6.3.1.2 Exploding Bridgewire Initiator. An initiator whose bridge wire must be vaporized in a few microseconds (usually five or less) by the direct application of electrical energy in order to effect initiation.

6.3.1.3 Conductive Mix Initiator. An initiator in which the bridge consists of a conductive explosive, propellant or pyrotechnic material which is in direct contact with the initiator contacts. Actuation is caused by passing current through the conductive material thereby heating it directly.

6.3.2 Bridge. A resistive element (usually in the form of a wire used to span the gap between two contacts) through which electric energy is converted to heat (also light and shock in exploding bridges) for the purpose of initiating an explosive, propellant, or pyrotechnic material directly.

6.3.3 Contact. That part of the bridge circuit, usually in the form of a wire or small metal rod, which serves to complete the electric circuit between the bridge and the electric connector of the power source.

6.3.4 Bridge Circuit. The open circuit containing the bridge, contacts and electric elements permanently in series or parallel with the bridge circuit. It does not include any electric elements connected externally to the contacts such as shorting or firing leads.

6.3.5 Bridge Circuit Gap. A non-linear resistive element, usually in the form of a spark gap or semiconductor, which forms a part of the bridge circuit and which limits the bridge circuit current until a potential equal to or greater than the bridge circuit gap breakdown is applied to the circuit.

6.3.6 Output. A measurable parameter, such as pressure, current, voltage, resistance, shock wave duration, dent, mechanical force, etc. which can be related to the expected performance of the initiator.

6.3.7 Minimum 50 Millisecond All-Fire Stimulus. The least firing stimulus which causes initiation within 50 milliseconds of not less than 99.0 per cent of all initiators of a given design at a level of confidence of 95 per cent. For electric initiators which contain a delay

element the firing stimulus should be applied for not less than 50 milliseconds, but the actuation time should be extended to include the maximum delay time specified for the delay element.

6.3.8 Firing Time. Firing time is the total elapsed time from the time of application of the firing all-fire stimulus to the time of initiator actuation, exclusive of delay element time, if present.

6.3.9 Maximum no-fire stimulus. The greatest firing stimulus which does not cause initiation within five minutes of more than 1.0 percent of all electric initiators of a given design at a level of confidence of 95 percent. For electric initiators which contain a delay element the firing stimulus should be applied for 5 minutes exclusive of delay element time if present.

6.4 Summary of some Problems in Applying Various Statistical Type Analyses. Various statistical type analyses have been prepared and are used in order to determine safety and reliability; for example: Bruceton method, Probit method etc. Statisticians have pointed out the fallacy of a blanket use of these various methods and the extreme care necessary in their application. Much effort is being conducted in search of an ideal method for this type of testing. AMP Report No. 101.1R SRG – PN 40 or NAVORD Report No. 2101 in conjunction with an article (“A Statistical Precise Method of Estimating the Bio-Assay and Quantal Response, Based on the Logistical Distribution Function”) in the Journal of American Statistical Association 48, pages 565-599, September, 1953 elucidates on one of the methods. In light of these difficulties, the only really safe method of reliability testing is the standard, GO, NO-GO type.

6.5 Subject Term (Key Word) Listing.

Igniters
Fuzes

6.5 Changes from previous issue. Marginal notations are not used in this revision to identify changes with respect to the previous issue due to the extensiveness of the changes.

EXPLODING FOIL INITIATOR (EFIs) CERTIFICATION

A.1 SCOPE

A.1.1 SCOPE. This appendix furnishes general requirements for the certification of Exploding Foil Initiators (EFIs) that are used for safety sensitive initiation applications. The purpose of the certification program is to establish fundamental EFI characteristics including the electrical response characteristics, soundness of mechanical design, output, basic safety properties and resistance to deleterious service environments. The requirements in this document are considered to be the minimum for certification of any EFI. The certification provided for in this document will normally be an interim step toward type certification of an EFI in a system, and will typically be supplemented by additional testing peculiar to the specific service application for which the EFI is intended. Multi-point initiation systems with multiple explosive outputs (multi-point initiators) are not specifically covered by this document. The individual EFI, used in a multi-point system, can be evaluated as specified herein when the tests are applicable. Any EFI with a single explosive output containing two or more bridges for reliability purposes should be evaluated with only one bridge energized in the tests. This appendix is a mandatory part of the specification. The information contained herein is intended for compliance.

A.2 APPLICABLE DOCUMENTS

MIL-STD-202	Electronic and Electrical Component Parts
MIL-STD-331	Fuze and Fuze Components Environmental and Performance Test for
MIL-STD-1316	Fuze Design, Safety Criteria For
MIL-STD-1751	Safety and Performance Tests for Qualifications of Explosives
MIL-STD-1901	Munition Rocket and Missile Motor Ignition System Design, Safety Criteria For
MIL-STD-1911	Hand-Emplaced Ordnance Design, Safety Criteria For

A.3 DESCRIPTION

A.3.1 General.

a. This document is intended for use for EFIs that contain only explosives that have been certified per MIL-STD-1751 for in-line use and require high stimulus levels (over 500 volts to initiate. These characteristics make them suitable for in-line applications (i.e., leading, without interruption, directly to the warhead, rocket motor, or other significantly hazardous quantity of explosive). EFIs are also commonly referred to as “slapper detonators”. The term EFI does not include complete assemblies, which have EFI’s as subassemblies, but include only the subassemblies themselves.

b. The initiator shall be tested in accordance with Table A-1. The EFIs are divided into test groups, which are shown in the top of the columns in the table. The required test titles are shown on the left of the table rows. This test sequence includes both qualitative and quantitative

statistical testing to meet safety and reliability requirements. All safety related electrical requirements must be met by the inherent characteristics of the EFI's bridge/explosive interface, not via augmentation with protective design features or devices. The 300 firings required in the All-Fire testing, if passed with no failures, is sufficient to provide a binomial reliability estimate slightly in excess of 0.99 at 95% confidence.

c. The certification of an EFI is dependent upon the fireset used during the certification. If a previously certified EFI is to be used with a different fireset, the following tests will need to be repeated: Firing Properties, All-Fire, and High Firing Voltage.

A.4 REQUIREMENTS

A.4.1 General. Tests shall be performed in accordance with Table A-1, in the sequence shown.

TABLE A-1. EFI CERTIFICATION

REQUIREMENT	TEST	30 A	30 B	30 C	30 D	5 E	10 F	30 G	30 H	50 I	50 J	50 K	50 L	50 M	50 N	5 O	500
A4.2 VISUAL INSPECTION	A6.1.1	X	X	X	X	X	X	X	X	X	X	X	X	X	X	X	500
A4.3 RADIOGRAPHIC EXAMINATION	A6.1.2	X	X	X	X	X	X	X	X	X	X	X	X	X	X	X	500
A4.4 BRIDGE CIRCUIT RESISTANCE	A6.1.3	X	X	X	X	X	X	X	X	X	X	X	X	X	X	X	500
A4.9 LEAKAGE	A6.6	X	X	X	X	X	X	X	X	X	X	X	X	X	X	X	500
A4.5 FIRING PROPERTIES, AMB	A6.2	X															30
A4.5 FIRING PROPERTIES, COLD	A6.2		X														30
A4.5 FIRING PROPERTIES, HOT	A6.2			X													30
A4.6 MNDC	A6.3				X												30
A4.7 THERMAL COO-KOFF	A6.4					X											5
A4.10 ELECTRICAL COOK-OFF	A6.7						X										10
A4.11 MAXIMUM ALLOWABLE ELECTRICAL SENSITIVITY	A6.8							X									30
A4.12 1.5 METER DROPS	A6.9								X	X	X	X					180
A4.13 ELECTROSTATIC DISCHARGE	A6.10												X				50
A4.8 TEMPERATURE SHOCK/HUMIDITY	A6.5								X	X	X	X					180
A4.14 VIBRATION	A6.11								X	X	X	X					180
A4.15 SHOCK	A6.12								X	X	X	X					180
A4.2 VISUAL INSPECTION	A6.1.1								X	X	X	X					180
A4.3 RADIOGRAPHIC EXAMINATION	A6.1.2								X	X	X	X					180
A4.4 BRIDGE CIRCUIT RESISTANCE	A6.1.3								X	X	X	X					180
A4.9 LEAKAGE	A6.6								X	X	X	X					180

MIL-DTL-23659E
APPENDIX A

A4.16 ALL FIRE PERFORMANCE, AMB	A6.13									X			X					100
A4.16 ALL FIRE PERFORMANCE, COLD	A6.13									X			X					100
A4.16 ALL FIRE PERFORMANCE HOT	A6.13									X			X					100
A4.5 FIRING PROPERTIES, AMB	A6.2							X										30
A4.17 HIGH FIRING VOLTAGE	A6.14																X	5

A.4.1.1 Test Documentation. Test plans, performance records, equipment, conditions, results, and analyses shall be documented. A detailed certification test plan shall be developed and approved by the appropriate safety authority prior to starting the certification tests. The detailed certification test plan shall provide descriptions of the following: visual inspections and examinations, fireset, test fixtures, the test firing circuit, and special test equipment that will be used in conducting each test. A detailed test report shall be provided to the design safety authority at the completion of the certification testing. At a minimum this report shall include the test data, inspection results, diagnostic records, and explanation of anomalous results.

A.4.1.2 Pre-test Certification. Prior to initiating the test sequence, documentation shall be available to certify that all of the EFIs to be used in this certification meet the manufacturer’s requirements with respect to workmanship, marking, and conformance to drawings.

A.4.1.3 Design Rejection and Retest Criteria. Failure of any initiator to conform to the requirements of this specification shall be cause for rejection of the design. Before the tests are repeated, full particulars concerning the failure(s) and action taken to correct the defects shall be submitted for approval to the appropriate safety authority.

A.4.2 Visual Inspection. The EFI shall be visually examined and meet the manufacturer’s incoming visual inspection criteria.

A.4.3 Radiographic Examination. Each initiator shall be subjected to radiographic examination such as X-ray, neutron bombardment, gamma rays, etc. Radiographic plates shall be identified by date, initiator part number, lot number, date of manufacture, and manufacturer’s identification.

A.4.4 Bridge Circuit Resistance. Each initiator shall be subjected to a bridge circuit resistance test. The resistance measured shall be within manufacturer’s acceptance criteria. During the course of the certification testing, if the bridge circuit resistance changes in either direction by more than 5% from the initial value, an evaluation to determine the cause shall be performed and provided to the design safety authority.

A.4.5 Firing Properties. The firing properties shall be determined by statistical tests for a sample of no fewer than 30 EFI each at hot, cold and ambient temperatures. The appropriate safety authority shall approve the test procedures and the associated statistical analysis methods used. Firing circuitry shall be in accordance with paragraph A.5.1. In addition to reporting the

reliability levels, all raw data recorded for the sensitivity tests that comprise the firing properties test shall be reported along with the mean firing voltage and the associated standard deviation.

A.4.5.1 Minimum All-Fire Voltage, (MAFV). Statistical analysis of the firing properties data shall be used to predict a minimum all-fire voltage for a firing reliability of 0.999 at 95% confidence at each temperature.

A.4.5.2 Maximum No-Fire Voltage, (MNFV). Statistical analysis of the firing properties data shall be used to predict a maximum no-fire voltage at all temperatures. MNFV is defined as the projected voltage at which the initiator has at most a .001 probability to fire with 95% confidence.

A.4.5.3 Maximum Allowable Safe Stimulus, (MASS). Statistical analysis of the firing properties data shall be used to predict MASS at all temperatures. MASS is defined as the projected voltage at which the initiator has at most a 10^{-6} probability to fire with 95% confidence. The EFI MASS shall be greater than 500 Volts at all temperatures tested.

A.4.5.4 Fuze Arming Voltage (FAV). Statistical analysis of the firing properties data shall be used to predict a voltage normally assessed as the fuze arming point at all temperatures. FAV is defined as the estimated voltage at which the initiator has a 0.005 probability to fire at 95% confidence.

A.4.6 Maximum No-Damage Current, (MNDC). A statistical test series at ambient temperature shall be conducted to determine the mean DC current level required to damage the EFI. The mean DC current level shall be above 1 ampere.

A.4.7 Thermal Cook-Off. The reaction of the EFI when subjected to a thermal cook-off environment will be determined.

A.4.8 Temperature-Shock/Humidity. The initiator shall be capable of withstanding temperature-shock/humidity without damage or performance degradation.

A.4.9 Leakage.

A.4.9.1 Hermetically Sealed EFI. An hermetically sealed EFI shall not exhibit a leak rate in excess of 10^{-5} cc per second of air at a pressure differential of at least 0.9 atmosphere.

A.4.9.2 Non-Hermetically Sealed EFI. A non-hermetically sealed EFI shall meet the Safety Authority's requirements.

A.4.10 Electrical Cook-Off. The reaction of the bare EFI to exposure to common AC and DC voltage sources up to 500 volts shall be determined. Test circuitry for the AC test shall be in accordance with paragraph A.5.2. An EFI will not be considered for certification for non-interrupted explosive train use if the reaction is a detonation. If the EFI is intended for use as a stand alone configuration item, or an application in which the leads of the EFI may be externally

exposed or accessible, the initiator shall not exhibit a functional explosive reaction (deflagration, explosion, or detonation) during this test.

A.4.11 Maximum Allowable Electrical Sensitivity. The electrical sensitivity of the initiator shall be determined by statistical tests for a sample of no fewer than 30 EFI. The appropriate safety authority shall approve the test procedures and the associated statistical analysis methods used. Firing the firing circuitry used for this test shall be in accordance with paragraph A.5.3. Statistical analysis of the electrical sensitivity data shall be used to predict the Standard No-Fire Voltage (SNFV). The SNFV is defined as projected voltage at which the initiator has a .001 probability to fire with 95% confidence. In addition to reporting the SNFV, all raw data recorded for the sensitivity test shall be reported along with the mean firing voltage and the associated standard deviation. The EFI SNFV shall be greater than 500 volts.

A.4.12 1.5 Meter Drops. The initiator shall be safe and operable when dropped from a height of 1.5 meters.

A.4.13 Electrostatic Discharge. The EFI or shall not function or dud when subjected to simulated human body electrostatic discharge.

A.4.14 Vibration. The EFI shall be capable of withstanding vibration without damage or performance degradation.

A.4.15 Shock. The EFI shall be capable of withstanding mechanical shock without damage or performance degradation.

A.4.16 All-Fire Performance. The EFI shall fire and produce the required output when initiated at the minimum firing voltage intended for use with the EFI while temperature conditioned to ambient ($+23^{\circ} \pm 10$ C), hot (minimum of $+71^{\circ}$ C), and cold (maximum of -54° C).

A.4.17 High Firing Voltage. Determination of the EFI functional performance shall be made when initiated by a firing potential at voltage potentials 50% above the intended all-fire voltage or at the maximum limits of the intended use fireset, which ever is less.

A.5 EQUIPMENT

Suitable precision instrumentation shall be used, e.g. volt meter, ohm meter, temperature recorder, accelerometer, transient recorder, storage oscilloscope, transducers, current viewing resistor (CVR), strain gages, etc. Documented calibration records, as whole or individual components shall be maintained for reference. Digital recorders, storage oscilloscopes, etc., shall be capable of reciprocal sample rates that are a maximum of one fifth the time resolution required to acquire data. Unless otherwise specified all electronic voltages, currents, and resistance shall be accurate to a tolerance of 1% or less.

A.5.1 Firing Properties Firing Unit. The firing unit for the firing properties tests and the all-fire tests shall be as close as possible to the intended use firing unit configuration, preferably

using the same components. Firing switches that will not operate in the same voltage range as the intended firing switch shall not be substituted. The test firing unit shall have transient firing properties that are within 25% to that of the intended use firing properties after modifications are made to measure the necessary data (such as the addition of a current viewing resistor). The components shall not be used beyond their life ratings (e.g. spark gaps rated for forty discharges shall not be used more than forty total times). Firing units should be calibrated before the first test to assure the discharge properties (ring downs) are acceptable, and the subsequent discharges monitored for changes, such as signs of component deterioration.

A.5.2 Electrical Cook-Off Tester, AC. A special test set is required. The test set must be capable of being controlled to RMS output potential of 440 VAC; further, the test set must be capable of delivering current without throwing the circuit breaker during the course of the test sustaining a short circuit current for five minutes. The output of the tester must be controlled to switch voltage on within 10% of the peak voltage value, with a controlled turn on transient.

A.5.3 Maximum Allowable Electrical Sensitivity Firing Unit. The firing unit for the electrical sensitivity tests shall be defined by the following:

- a. The high voltage capacitor shall have a capacitance of $0.1 \mu\text{F} - 0\% + 20\%$.
- b. The diagnostic component in the test set shall be calibrated and may be either a current viewing resistor (CVR) or a current viewing transformer (CVT) or both.
- c. The high voltage switch must demonstrate a wide dynamic range, be extremely efficient, and must be reproducible shot to shot. Additionally, the switch used should be linear to within 5% when peak current is plotted against charge voltage for ringdowns across the voltage range to be tested. The voltage range tested shall include a minimum of 5 ringdown levels equally spaced across the voltage range. High voltage vacuum relays, semiconductor switches, and shock switches are acceptable as long as they deliver a minimum of 90% of the capacitor energy into a 0.5 ohm load consistently.
- d. Two loads shall be used to evaluate the test set. A short at the output connector and low inductance resistor of 0.5Ω shall be used to represent the range of dynamic impedances of the EFI.
- e. A schematic of the Capacitor Discharge Unit (CDU) is shown in Fig. A-1.
- f. A minimum of three discharges of the firing unit (ringdowns) shall be performed at two voltages (500 and 1000 volts) using each of the loads and shall meet the requirements for the parameters listed in Table A-2 as defined in Figs. A-2 and A-3.
- g. The minimum circuit inductance shall be no less than 20 nano henries and no greater than 35 nano henries.

A.5.3.1 Performance. The performance of the test set when shorted at the output connector is illustrated in Fig. A-2. The parameters of interest are defined in the figure and their values are listed in Table A-2. The amount of energy delivered to the load and the rate that it is delivered during the first half cycle of a capacitor discharge is a measure of importance for EFI response. A measure of the area under discharge curve and the rise time should be able to arbitrate the efficiency of the fireset, see Fig. A-3.

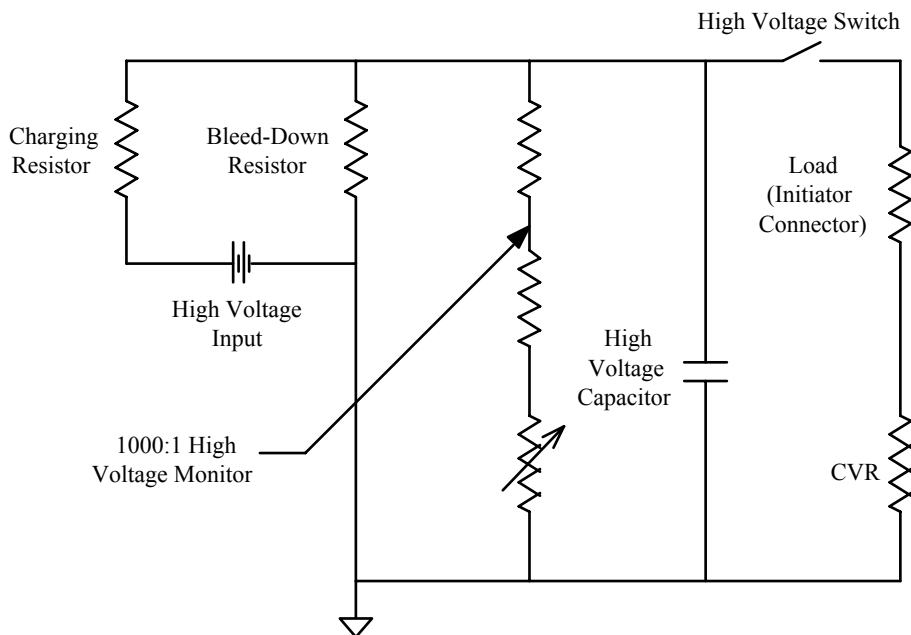

FIGURE A-1. Fireset Schematic

TABLE A-2. Standard Fireset Parameter Requirements at 500 and 1000 volts

Load	Short at 500 Volts (Ringdown)	0.50 Ω load at 500 Volts	Short at 1000 Volts (Ringdown)	0.50 Ω load at 1000 Volts
10% to 90% Risetime (t_r)	93 ns max.	105 ns max.	93 ns max.	105 ns max.
Time to first peak	83 ns min.	95 ns min.	83 ns min.	95 ns min.
First Peak Current (I_1)	800 Amps minimum	380 Amps minimum	1700 Amps minimum	780 Amps minimum
Second Peak Current (I_2)	490 Amps minimum	NA	1150 Amps minimum	NA
Period (Δt)	430 ns maximum	N/A	425 ns maximum	N/A
Delivered Energy (area under discharge curve* Load Resistance) $\int_0^{P+2} i^2 R dt$	N/A	9.5 mJ	N/A	40 mJ

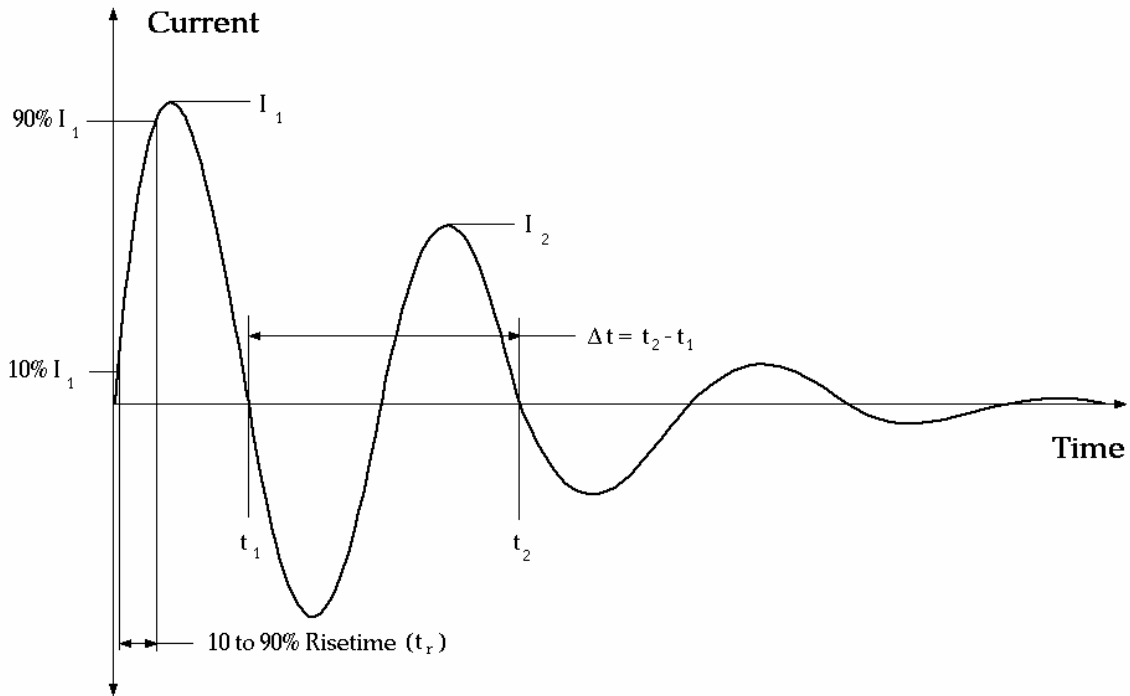

FIGURE A-2. Typical Ringdown Curve Into a Short

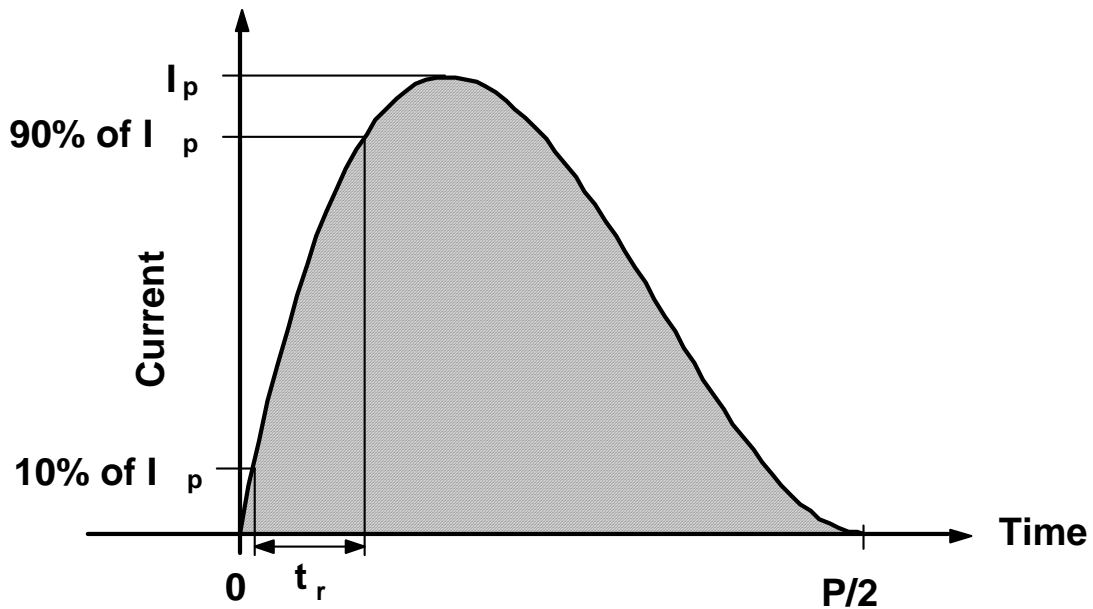

FIGURE A-3. Typical Waveform Into a 0.50Ω Load for Calculation of the Area Under The Discharge Curve ($\int_0^{P/2} i^2 R dt$) And Rise Time (t_r)

A.6 TEST PROCEDURES

A.6.1 Pre-Test Certification. The manufacturer shall examine each EFI per manufacturing instructions prior to beginning the test sequence. Certification that all inspection requirements have been met shall be supplied.

A.6.1.1 Visual Inspection. The Each EFI shall be visually inspected in accordance with the manufacturer's acceptance criteria.

A.6.1.2 Radiographic Examination. Each EFI shall be subjected to radiographic examination such as X-ray, neutron bombardment, gamma rays, etc. and the radiographic plates shall be examined for defects in accordance with the manufacturer's acceptance criteria.

A.6.1.3 Bridge Circuit Resistance. Each EFI bridge current resistance shall be measured with an accuracy within 2.0 percent (maximum) using a test that subjects the bridge to a current of less than 100 milliamperes. These tests shall be conducted in accordance with MIL-STD-202, method 303, except the measurement shall be corrected to 25^o C.

A.6.2 Firing Properties. To determine the firing properties, the EFI shall be energized from the firing unit of paragraph A.5.1 . The firing capacitor voltage shall be varied according to the requirements of the statistical test used. In each case, the voltage shall be adjusted to within 1% of the required value. EFI and the firing unit used for this test shall be temperature conditioned at the test temperature for a minimum time of 12 hours. Alternatively, the EFI can be conditioned until the temperature of the tested units stabilizes as determined by thermocouples deeply buried in the assembly or in surrogate inert assemblies conditioned along side of the test units. The conditioning duration and logic used for selecting less than 12 hours shall be documented and assemblies photographically recorded. The EFI shall be temperature conditioned to ambient, hot, and cold at temperatures. Effort shall be made to assure that the EFI meets the temperature requirements at the moment it is functioned. Cold temperature shall be a maximum of -54 C (-65°F), ambient temperature shall be +23 ± 10 C (+73 ± 18°F), and hot temperature shall be a minimum of +71 C (+160°F).

A.6.3 Maximum No-Damage Current, (MNDC). The EFI's input leads shall be subjected to DC current levels in accordance with an accepted statistical method similar to that used for the firing properties test (Bruceton, Langlie, Neyer, etc.). The EFI shall be subject to DC current in a bare condition and conducted at a temperature of +23 +/- 10 C. The applied current shall not overshoot the intended test current level by more than 5%. The full test current shall be applied for a minimum of 1 minute. The period of time that the current is rising to the intended test current shall not apply to the 1 minute of test time. Assessment of damage or no-damage at each test level shall be made by the application of operational voltage from the intended fireset. If the operational voltage is unknown or undefined, the MAFV determined in the firing properties test shall be used. A detonation that meets the EFI's specified output criteria shall be considered evidence of no damage while failure to do so shall be assessed as a damaged result. Results shall be analyzed statistically and the mean and standard deviation of the no damage current shall be reported.

A.6.4 Thermal Cook-Off. The EFI will be placed in a fixture that provides radial confinement and a dent block identical to those used for output determination, placed in contact with the output end. The radial confinement used shall be a right circular cylinder constructed from steel. The outside of the cylinder shall have a radius that is at least 50% larger than the radius of the EFI being tested. Additionally the cylinder shall have a center hole to accommodate the EFI whose radius is sized such that there is a maximum radial gap of 0.0018” between the outside surface of the EFI and the inside surface of the hole. The radially confined EFI shall be mechanically anchored to the dent block to prevent movement should a reaction occur. These assemblies shall be placed in an oven at ambient temperatures and the temperature increased at a rate of

3.3 °C per hour until all EFIs react. In the reaction of the EFI is not easily detectable, the test may be terminated at a temperature 10° C above the decomposition temperature of the most thermally stable energetic material used in the EFI. In order to reduce test time, a starting temperature in excess of ambient is allowed as long as the time interval between the start of the test to EFI reaction is a minimum of 16 hours. The temperature and time at which the cook-off reaction occurs and the dent produced by the cook-off reaction shall be documented.

A.6.5 Temperature-Shock/Humidity. Temperature-shock/Humidity cycling between -54°C and +71°C (-65°F to and +160°F respectively) in accordance with the two-chamber method of MIL-STD-331, test C1. The transfer times between the two chambers shall be less than two minutes.

A.6.6 Leakage

A.6.6.1 Hermetic Devices. Perform the Fine Leak Test in accordance with MIL-STD-331, test C8.

A.6.6.2 Leakage – Non Hermetic Devices. Perform Leak Test in accordance with Safety Authority’s requirements.

A.6.7 Electrical Cook-Off. The EFI shall be subjected to the following AC and a DC electrical cook-off tests.

A.6.7.1 AC Test. The input to the EFI shall be energized from a 60 hertz AC source at 440 VAC; the power source must be capable of sustaining a minimum short circuit current of 20 amperes. Maximum line impedance of the tester shall be 22 Ω at 1000 watts. The minimum open circuit voltage of the source shall be adjusted to within 5 percent of the required value. EFI used for this test shall be temperature conditioned at +23°C +/- 10°C. Five EFI shall be exposed to the 440 volts RMS for five minutes or until the reaction ceases, which ever occurs first. Each EFI shall be confined with radial confinement and a dent block for output measurement as described in paragraph A.6.4. The radially confined EFI shall be mechanically anchored to the dent block to prevent movement should a reaction occur. The dent blocks shall be mechanically anchored to prevent movement should any reaction/transition to detonation occur. For the test, the input voltage shall be switched on either mechanically or electronically, and the onset of voltage shall be controlled. Means of switching power shall be capable of a rise time of 1

microsecond, maximum, to full voltage into a 2.5 ampere resistive load, with the rise time occurring while the amplitude of the applied voltage is within 10% of the peak value. The reaction of each EFI shall be documented. Video or high speed optical recordings shall be used, along, with the dent block condition, to capture response characteristics.

A.6.7.2 DC Test. The input to the EFI shall be energized from a DC source at 28 volts; the power source must be capable of sustaining a minimum short circuit current of 10 amperes. The open circuit voltage of the source shall be adjusted to within 5 percent of the required value. Each EFI used for this test shall be temperature conditioned at $+23^{\circ}\text{C} \pm 10^{\circ}\text{C}$. Five EFIs shall be exposed to the 28 volts DC for five minutes or until the reaction ceases, whichever occurs first. The EFI shall be confined as described in the AC test. The EFIs shall be confined top and bottom between dent blocks identical to those used for output measurements. The dent blocks shall be mechanically anchored to prevent movement should any reaction transition to detonation occur. For the test, the input voltage shall be switched on either mechanically or electronically, and the onset of voltage shall be controlled in the following manner. The means of switching power shall be capable of a rise time of 1 microsecond, or less, to full voltage. The reaction of each EFI shall be documented. Video, or high speed optical, recordings shall be used along with the dent block condition to capture response characteristics.

A.6.8 Maximum Allowable Electrical Sensitivity. To determine the electrical sensitivity, the EFI shall be energized from the firing unit of paragraph A.5.3. The firing capacitor voltage shall be varied according to the requirements of the statistical test used. In each case, the voltage shall be adjusted to the required value and measured with an accuracy of at least 2% volt. EFI and the firing unit used for this test shall be temperature conditioned for a minimum time of 12 hours at ambient temperature (23 ± 10 C).

A.6.9 1.5 Meter Drops. Test the EFI by dropping them in random orientations 1.5 meters in accordance with MIL-STD-331, test A4.1.

A.6.10 Electrostatic Discharge. Test the EFI pin to case in accordance with MIL-STD-331, test F1.1. Testing of the EFI pin to pin need not include the 5000 ohm resistor in series, use of the 500 ohm resistor in series with the EFI is mandatory.

A.6.11 Vibration. EFI shall be tested in accordance with MIL-STD-331, Test B3, using the level of Table B3-1 for general use fuzes. The EFI shall be temperature conditioned at -54°C , $+23^{\circ}\text{C}$, and $+71^{\circ}\text{C}$ (-65°F , $+73^{\circ}\text{F}$, and $+160^{\circ}\text{F}$) cold, ambient, and hot temperatures during vibration exposure. Cold temperature shall be a maximum of -54 C (-65°F), ambient temperature shall be $+23 \pm 10$ C ($+73 \pm 18^{\circ}\text{F}$), and hot temperature shall be a minimum of $+71$ C ($+160^{\circ}\text{F}$).

A.6.12 Shock. The EFI shall be mounted in a suitable test vehicle simulating the expected mounting of the device and tested in accordance with the shock test in accordance with MIL-STD-202. The shock pulse shall be a half sine pulse. The amplitude of each shock pulse shall exceed 2000 g's and have a minimum duration of 0.5 milliseconds.

A.6.13 All-Fire Performance. Prior to firing, the test items and their firing circuitry shall be temperature conditioned and maintained at the required temperature for 12 hours, or until the temperature stabilizes at the desired level, whichever is shorter. If the EFI cannot be test fired within the temperature chamber, a test protocol shall be established that guarantees the EFI is at the desired temperature. The conditioning temperature, duration out of the chamber, and logic used for this testing protocol shall be documented. Whenever it is necessary to repeat cold temperature conditioning of a cold device, all condensation shall be removed from the device before it is returned to the temperature-conditioning chamber. Effort shall be made to assure that the EFI meets the temperature requirements at the moment it is functioned. The EFI shall be fired from the firing unit of A.5.1. The output shall be measured and shall conform to the EFI's acceptance criteria.

A.6.14 High Firing Voltage. The EFI shall be fired from the firing unit described in A.5.1 charged to the limits of the firing system, or to 150% of the maximum intended use firing voltage, which ever is less. The output shall be measured and shall conform to the EFI's acceptance criteria.

A.7 RELATED INFORMATION

A.7.1 General. This section contains information, for guidance only, of a general explanatory nature that may be useful but is not mandatory. Some of the material in the notes is to assist in understanding the basis for the requirements.

A.7.2 Intended Use. This specification is intended to prescribe tests and test procedures for the evaluation of EFI's by subjecting them to characterization, environmental, and functional tests to establish basic electrical and functional performance of the EFI.

A.7.3 Test Documentation. It is always advisable to generate test plans, performance records, equipment, conditions, results, and analyses when conducting any certification. A detailed certification test plan should be developed and approved by the appropriate safety authority prior to starting the certification tests. The detailed certification test plan should provide descriptions of the following: visual inspections and examinations, fireset, test fixtures, the test firing circuit, and special test equipment that will be used in conducting each test. A detailed test report should be provided to the design safety authority at the completion of the certification testing. At a minimum this report should include the test data, inspection results, diagnostic records, and explanation of anomalous results.

A.7.4 Safety Review. Safety approval of all safety-critical initiation systems is required for each munitions system. During that the review the EFI characteristics will be reviewed in detail.

A.7.5 Maximum No-Fire Stimulus. The firing properties test data can used to determine several points of general interest in the EFI operating characteristics, including Maximum No-Fire Stimulus (MNFS). MNFS is defined and is the same in all the initiation safety standards (MIL-STD-1316, MIL-STD-1901 and MIL-STD-1911) and reflects a commonly used probability point for an EFI -- the Maximum stimulus that will not fire an EFI. For most EFIs,

voltage is generally the stimulus of interest in determining MNFS. The firing properties test data can be used to determine Maximum No-Fire Stimulus (MNFS).

A.7.6 Test Specific Information. The following additional information is listed alphabetically. The purpose of the additional information is:

- a. Clarification of requirements that are frequently misinterpreted;
- b. Explanation of those requirements that are stated in a manner to allow for technological growth, but do not imply an obvious current solution;
- c. Historical information which may be useful in future specification reviews, or updates.

A.7.6.1 All-Fire Performance. Design and manufacturing flaws can exist that would not be discovered by a small number of test firings. Requiring the certification be performed on a larger number of EFIs limits the possibility that the manufacturing for the certification units will not be representative of production units. This test is to demonstrate the EFI has a reliability of at least 0.99 at 95% confidence after being subjected to common environmental stimuli. To establish this reliability a test quantity of 298 EFIs must be fired with no failures in the all-fire performance tests. The EFI should be fired at the firing voltage intended for its application. These tests do not depend on the statistical all-fire voltage projection for device reliability. Some developers may propose to accept EFI designs on the basis of extrapolated projections of successful statistical properties. It is worth noting that it is possible to statistically project acceptable all-fire voltages using EFIs that are unreliable.

A.7.6.2 Electrical Cook-Off. The intent of this test is to establish the nature of the energetic reaction when an EFI is inadvertently subjected to a current source from commonly available power supplies. Reactions, for this test, include lower order reactions such as deflagration, upon exposure to commonly available power sources.

a. A detonation of the EFI during this test will eliminate the EFI from consideration for non-interrupted explosive train applications. In their assembled configuration within the fuzing system, MIL-STD-1316 requires electrically fired initiators used in non-interrupted applications to be incapable of being initiated by any electrical potential of less than 500 volts applied to any accessible part of the fuzing system. The term initiate is intended to include not only the design mode detonation, but also any energetic reaction of the explosive material contained within the EFI. As a result of this requirement no energetic reaction is allowed if the EFI is intended for use in a stand alone configuration item or if the leads to the EFI or the EFI assembly can be directly accessed for test or other instrumentation purposes at the munition level, or the level of a major munition subsection -- such as the warhead section. This is particularly important for systems where a low order reaction could result in a hazardous situation.

b. The test calls for the use of test voltages that are common line potentials. The test is to be performed using 28 VDC, and 440 VAC., Other voltage sources that have the potential to be inadvertently coupled to the EFI in its intended application should also be considered.

c. Circuit behavior can vary according to the onset waveform. For that reason the onset of voltage for this test shall be switched on in a controlled manner.

A.7.6.3 Maximum Allowable Electrical Sensitivity.

a. The intent of this test is to establish a fundamental electrical sensitivity threshold, below which an EFI must not detonate, if it is to be considered for use in a non-interrupted explosive train. This test is intended to serve as an implementation device for the current MIL-STD-1316 requirement that initiators used in non-interrupted explosive trains be incapable of being detonated by any electrical potential of less than 500 volts. The approach taken to accomplish this is to define a "Standard" fireset, which would be used by all EFI to establish the maximum allowable electrical sensitivity threshold level. The general idea is to have an adequately sized high voltage capacitor, coupled with a sufficiently efficient high voltage switch and associated circuitry, to insure adequate electrical insensitivity is provided for in the EFI design. When an EFI is capable of meeting the required threshold using this fireset, it would insure that the EFI inherently had a sufficient degree of electrical insensitivity to be used in non-interrupted explosive train applications. This approach may be limited in applicability to EFI designs as we currently understand them, and significantly different technologies may require definition of alternate test methods.

b. The "Standard" fireset is not related to the intended-use fireset, and is to be used for this test only. It is recognized that the details established for the "Standard" fireset are somewhat subjective. The goal in establishing the details is to strike an acceptable balance between ensuring an adequate degree of safety is provided for by the selected insensitivity threshold, and avoiding driving EFI/fireset designs to impractical design solutions. If the design fireset produces input stimulus which envelopes or exceeds that of the standard fireset, the maximum allowable electrical sensitivity test may not be required.

A.7.6.4 Firing Properties.

a. The purpose of the firing properties tests is to establish required electrical initiation characteristics of the EFI. The firing properties test establishes statistical characteristics that can be used for selecting or verifying the following: the design's recommended all-fire voltage, the maximum no-fire voltage, and the maximum allowable safe stimulus. These parameters can be used for the evaluation of an EFI's suitability for an application and/or in the establishment of thresholds for safety critical states. For example, in MIL-STD-1316, ESADs containing firing capacitor voltages above MNFV are considered armed, thus the determination of MNFV via the firing properties test can be used to determine the arming point for evaluation of safe separation requirements.

b. EFI that are capable of being detonated at potentials less than 500 volts cannot be used in any non-interrupted explosive train application governed by the existing military safety standards (MIL-STD-1316, MIL-STD-1901 or MIL-STD-1911). At a minimum, firing characteristics established under this test must be used to establish compliance with this requirement.

c. Various statistical type analyses have been prepared and are used in order to project safety and reliability characteristics: for example: Bruceton, Neyer, Langlie and Probit Methods.

Statisticians have pointed out the fallacy of an inappropriate use of these various methods and the extreme care necessary in their application.

d. MNFV, Maximum No-Fire Voltage determination is important for use in safety evaluations, see the example in paragraph A.7.6.4 a. Voltage is a commonly used parameter in defining the test inputs in capacitive discharge firing system evaluations. A knowledge of voltage potential effects can also be important for evaluating powered ESADs, whose electronics if subverted by noise or electromagnetic radiation could develop a voltage on the high voltage capacitor. The probability level established by this test was selected to correspond with the probability typically used in the Hazards of Electromagnetics to Ordnance (HERO) community.

e. MASS, Maximum Acceptable Safe Stimulus can be any stimulus that is unsafe - voltage, current, light, etc. MASS, for this test is also characterized as a voltage, and is represented as the voltage on the firing capacitor at which the probability of detonation is 10^{-6} .

f. While 12 hour temperature conditioning is specified for this, and several other tests, the duration could be tailored to suit the test hardware. The intent is that the temperature of the test item has stabilized at the test temperature, which often will require less time for small test items. When determining temperature stabilization times, all the test hardware should be considered, including the test item and, where necessary, firing unit components. The conditioning duration and logic used for selecting less than 12 hours shall be documented. Effort shall be made to assure that the EFI meets the temperature requirements at the moment it is functioned. This requirement may be met by employing a test methodology of conditioning to a temperature more extreme than the requirement and monitoring the time needed to function the EFI.

A.7.6.5 Maximum No Damage Current (MNDC). The intent of this test is to establish the lowest level electrical input which that could result in damage of the EFI. This level would be used in evaluating inadvertent RF damage susceptibility at the system level. As a check to insure that a potential safety hazard involving the inadvertent activation of an energetic material reaction within the initiator is not over looked, a minimum threshold must be exceeded by the mean MNDC. This threshold value has been established based on past safety critical Electro-explosive Device (EED) no-fire requirements and is believed not to create a technical challenge within the existing state of the art for EFIs. This requirement is based on the assumption that the current level that is capable of damaging the EFI is lower than the current level required to cause a reaction of the energetic material within the EFI. If mean MNDC does not met the threshold requirement, or if an energetic reaction within the EFI can occur below the mean MNDC, the developer is to consult the cognizant safety authority for direction.

A.7.6.6 Electrostatic Discharge. This test confirms minimum acceptable design safety and reliability characteristics of the EFI with respect to inadvertent ESD inputs. There are two ways an EFI can be damage by ESD, each case could influence device reliability and safety. The first way an EFI can be damage by ESD is when the damage occurs by a breakdown of the EFI insulation when potential is developed between the pin and case of the EFI. The pin to case test with the 5000 ohm resistor in series with the EFI may be more severe than when the 500 ohm is in series because the longer pulse duration may increase the probability of a breakdown even though less potential is developed. Therefore, pin-to-case tests with each resistor in series with

the EFI are required. The second way an EFI can be damage by ESD is when the bridge is heated by potential between the pins of the EFI. The energy delivered through a 500 ohm resistor to the EFI is greater than that delivered through a 5000 ohm resistor. If the device passes the test with a 500 ohm resistor, it will also pass with a 5000 ohm resistor. Therefore, pin-to-pin tests with the 500 ohm resistor only in series with the EFI are required. It is unlikely to expect any damage, much less a reaction in the pin-to-pin mode for EFIs. Simple calculation shows that the maximum current into a detonator from a capacitor charged to 25,000 volts through a 500 ohm resistor is 50 amps, or almost 2 orders of magnitude less than a typical EFI burst current. Since the RC time constant is around 0.25 microseconds, the current drops off to nothing in a few hundred microseconds. The total energy in the capacitor is 156 millijoules. For a typical bridge of 50 milliohm resistance, only 1/10,000 of the energy is deposited in the bridge because the 500 ohm resistor in series absorbs most of the energy. Thus, the total energy that can ever be deposited in the bridge is on the order of 16 microjoules. Over time, as EFIs are tested pin-to-pin without damage, the pin-to-pin testing requirement may be eliminated, once enough confidence is developed that EFIs are immune pin to pin ESD.

A.7.6.7 High Firing Voltage. It may not be true that all EFIs are more reliable as the input firing voltage is increased. The objective of the test is to determine if the EFI is reliable at firing potentials that significantly exceed the system's intended firing voltage. This test is to provide the developing agency information about the chosen EFI in terms of design margin over the expected application firing voltage.

A.7.6.8 Environmental Tests. The required test levels for temperature, shock, vibration, etc. are based on the levels that will cover most applications, but they do not cover the most severe environments EFI can be exposed to. For example, EFI in tandem warheads, penetrator bombs, or artillery should have vibration or shock environmental tests that exceed those specified herein. System-specific levels in excess of those specified can be added to the environmental sequence if beneficial, and must be applied during the type certification phase of system development.

A.7.6.9 Sensitivity Test and Analysis. This section provides some background information on sensitivity test and analysis methods that are used for estimating the reliability and safety of exploding foil initiators. Reliability and safety issues necessitate use of methodologies that can assure consistency in derivation of these estimates. Accepted test and analysis methods for estimating these parameters include the Langlie, Probit, One Shot Transformed Response and Neyer D-Optimal Test methods. Although test and analysis are independent functions, each unique test method is historically associated with a unique analysis technique. These methods and techniques are commonly referred to as sensitivity tests and analyses. Because exploding foil initiators have outputs that are not linearly linked to input they require the specialized test and analysis methods described here.

A.7.6.9.1 Objectives. The objective of sensitivity test and analysis methodologies used should be assurance that estimates derived are as accurate and precise as possible. The parameter to be estimated is the mean stimulus level at which some fraction of the samples of a specific exploding foil initiator design will always function, in the case of an all-fire test, or not function, in the case of a no-fire test. There are no methodologies capable of exact determinations of this parameter. There are no non-destructive methods available to obtain the

data needed. The tests described here are usually considered as destructive in nature and therefore, the test articles should not be re-used in the end item. The analysis portion of the method computes estimated all-fire or no-fire rating. These estimated ratings are computed at a specific reliability and confidence and are applicable to only the specific exploding foil initiator design tested.

A.7.6.9.2 Sensitivity Test Limitations Tests. All methods used are small sample based. Therefore error in the estimates will occur. Care must be exercised when choosing test stimulus levels during the tests. If empirical data on the specific design is not available to assist selection of test levels before start of the test then additional samples should be allocated to perform pre-test evaluations. All of the methods used here assume the distribution of the threshold stimulus levels is normal. It is simple to generalize this assumption and require that some function, such as a logarithm, of the threshold levels are normally distributed. None of the test methods will be able to determine if even a relatively large percentage of the exploding foil initiators are duds, that is, those that will not function at any voltage. Thus, threshold tests must always be backed up with testing a sufficient quantity at an all-fire voltage.

A.7.6.9.3 Reliability and Confidence Levels Tests. For illustrative purposes in this example, reliability and confidence level values of 0.99 and 95% upper confidence limit have been chosen. This is literally interpreted to mean that 95% of the time no more than 1 in 100 exploding foil initiators will fail to function at the estimated all-fire rating. Users of these computed values should be made aware that adding margin to estimated all-fire and no-fire values is standard practice. Explosive system reliability assessments should therefore use the minimum stimulus values that the ignition system delivers to the exploding foil initiator to assess realistic system level reliability. Figure A-4 shows an example of a typical probability curve that is obtained from analysis of sensitivity test data. The y-axis is plotted using probability scaling. The solid straight line in the center gives the best guess for the probability of functioning at the given voltage. Also shown is the 95% upper side confidence curve for this data. To interpret the confidence curves a horizontal line at the 99% probability level intersects the most likely and 95% upper confidence curves at approximately 1290 and 1375 volts respectively. Thus, 1375 volts is the 95% upper confidence limit for 99% probability of fire for this fireset and initiator.

A.7.6.9.4 Safety and Confidence Levels. Figure A-5 shows an example of a typical probability curve that may be obtained from analysis of sensitivity test data being used to predict safety. The y-axis is plotted using probability scaling. The solid straight line in the center gives the best guess for the probability of functioning at the given voltage. Also shown is the 95% lower side confidence curve for this data, the worst case from a safety viewpoint. To interpret the confidence curves a horizontal line at the .000001 probability of fire level intersects the most likely and 95% lower confidence curves at approximately 560 and 810 volts respectively. For safety analysis the 560 volt level represents the greatest hazard, with 500 volts representing the no-fire voltage where less than 1 in 1,000,000 units will respond.

MIL-DTL-23659E
APPENDIX A

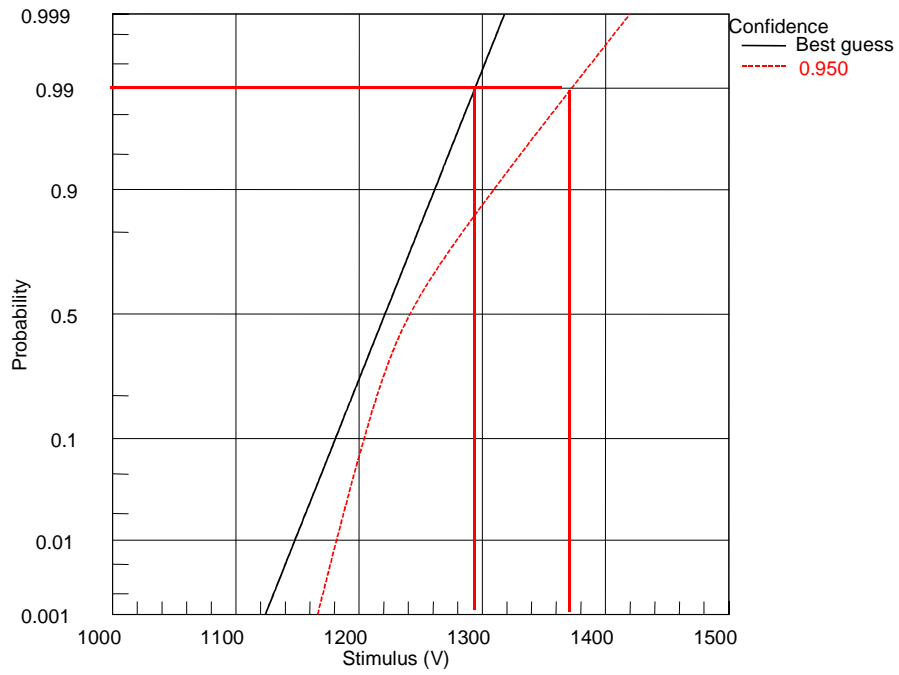

FIGURE A-4. Reliability Confidence Estimate

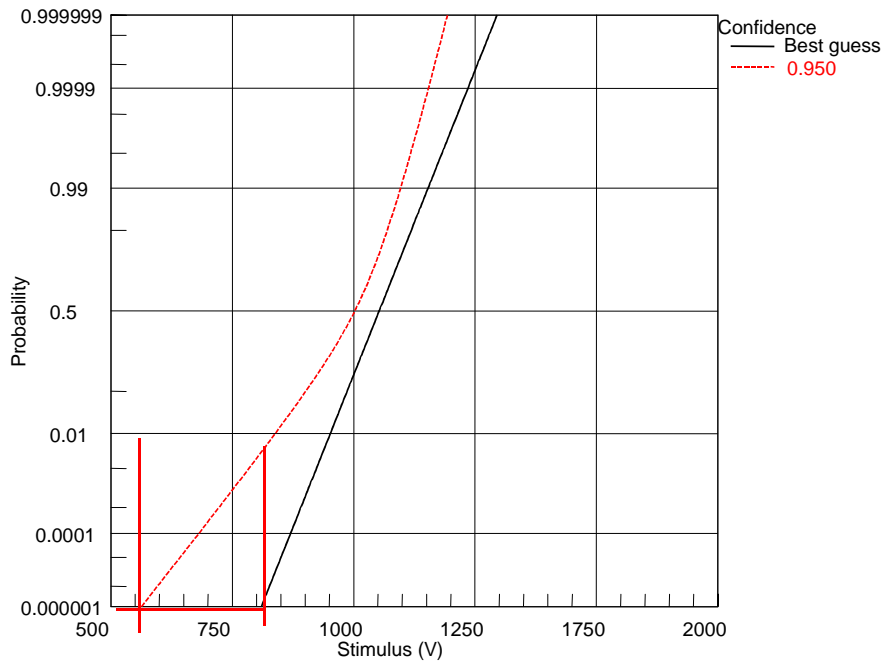

FIGURE A-5. Firing Safety Estimate

CONCLUDING MATERIAL

Custodians:

Navy – OS
Air Force – 11
Army – AR

Preparing Activity:

Navy – OS

(Project no. 1377-2007-015)

Reviewers:

Navy – NP
Air Force – 99, 70

NOTE: The activities listed above were interested in this document as of the date of this document. Since organizations and responsibilities can change, you should verify the currency of the information above using the ASSIST Online database at <http://assist.daps.dla.mil/>.