

# 22

SAFETY LIBRARY PUBLICATION

October 2019

## RECOMMENDATIONS FOR THE SAFE TRANSPORTATION OF DETONATORS IN A VEHICLE WITH CERTAIN OTHER EXPLOSIVE MATERIALS

EXPLOSIVES MAKE IT POSSIBLE

**IME**

institute of makers of explosives

## MEMBER COMPANIES (As of October 2019)

**Accurate Energetic Systems, LLC**

McEwen, Tennessee

**Austin Powder Company**

Cleveland, Ohio

**Baker Hughes**

Houston, Texas

**Daicel Safety Systems Americas, Inc.**

Mesa, Arizona

**Detotec North America, Inc.**

Sterling, Connecticut

**DynaEnergetics US, Inc.**

Houston, Texas

**Dyno Nobel Inc.**

Salt Lake City, Utah

**Enaex**

Salt Lake City, Utah

**General Dynamics OTS - Munition Services**

Joplin, Missouri

**GEODynamics Inc.**

Millsap, Texas

**Hilltop Energy**

Mineral City, Ohio

**Hunting Titan**

Houston, Texas

**Jet Research Center/Halliburton**

Alvarado, Texas

**Maine Drilling & Blasting**

Auburn, New Hampshire

**Maxam North America Inc.**

Salt Lake City, Utah

**MP Associates, Inc.**

Ione, California

**Nelson Brothers Inc.**

Birmingham, Alabama

**Nobel Insurance Services**

Irving, Texas

**Orica USA Inc.**

Watkins, Colorado

**Owen Oil Tools LP**

Godley, Texas

**RA McClure Inc.**

Powell, Ohio

**Safety Consulting Engineers, Inc.**

Schaumberg, Illinois

**Senex Explosives, Inc.**

Cuddy, Pennsylvania

**Teledyne RISI, Inc.**

Tracy, California

**Tread Corporation**

Roanoke, Virginia

**Vet's Explosives, Inc.**

Torrington, Connecticut

**Visible Assets**

Stratham, New Hampshire

**W.A. Murphy, Inc.**

South Pasadena, California

*Academic Members:*

**Colorado School of Mines**

Golden, Colorado

**University of Kentucky**

Lexington, Kentucky

**Missouri University of Science & Technology**

Rolla, Missouri

*Liaison Members:*

**Association of Energy Service Companies**

Friendswood, Texas

**Australian Explosives Industry & Safety**

**Group (AEISG)**

Tweeds Head, Australia

**Brazilian Association of Explosive and**

**Aggregate Materials Industries (ABIMEX)**

Sao Paulo, Brazil

**Canadian Explosives Industry Association**

**(CEAEC)**

Ottawa, Ontario, Canada

**Explosives Safety & Technology Society -**

**Visfotak**

Maharashtra, India

**Federation of European Explosives**

**Manufacturers (FEEM)**

Brussels, Belgium

**International Society of Explosives Engineers**

**(ISEE)**

Cleveland, Ohio

**National Institute for Explosives Technology**

**(NIXT)**

Lonehill, South Africa

**SAFEX International**

Christiansted, South Africa

# **IME**

**institute of makers of explosives**

**1212 NEW YORK AVENUE, NW  
SUITE 650  
WASHINGTON, DC 20005  
(202) 429-9280  
[www.ime.org](http://www.ime.org)  
[info@ime.org](mailto:info@ime.org)**

IME is a nonprofit association founded in 1913 to provide accurate information and comprehensive recommendations concerning the safety and security of commercial explosive materials. IME represents U.S. manufacturers and distributors of commercial explosive materials and oxidizers as well as other companies that provide related services. Although our member companies are based in North America, IME members operate globally with operations and distribution points on all continents except Antarctica.

IME was created to provide technically accurate information and recommendations concerning commercial explosive materials and to serve as a source of reliable information about their use. Committees of qualified representatives from IME member companies developed this information and a significant number of their recommendations are embodied in the regulations of state and federal agencies.

The Institute's principal committees are: Safety, Health and Environmental Affairs; Government Affairs, Legal Affairs; Technical; and Transportation, Distribution and Security.

### **DISCLAIMER (SLPs)**

IME has taken care in the preparation of the information contained in this Safety Library Publication (SLP) and believes it to be accurate. However, IME does not guarantee or warrant the accuracy, completeness or currency of the information contained in this SLP. Each user should review the information contained in this SLP in the specific context of the intended application. Anyone using this document should rely on his or her own independent judgment or, as appropriate, seek the advice of a competent professional in determining the exercise of reasonable care in any given circumstance. IME and its members are not responsible for, and do not accept liability for, any loss, expense, cost or damage of any nature resulting from the use of or reliance upon the information contained in this SLP. To the fullest extent permitted by law, IME disclaims all warranties, whether express, implied, statutory or otherwise, in relation to the information contained in this SLP.

## TABLE OF CONTENTS

	Page
<b>FOREWORD</b> .....	v
<b>BACKGROUND</b> .....	1
<b>COMPATIBILITY OF CLASS 1 MATERIALS</b> .....	1
<b>SLP-22 SPECIFICATIONS</b> .....	2
1. Applicable Products .....	2
2. Packaging, Labeling, Marking, and Loading .....	2
3. Construction .....	4
4. Identification .....	7
<b>APPENDIX A – EXPLOSIVES TRANSPORTATION CLASSIFICATIONS</b> ...	9

## **SLP-22**

### **Recommendations for the Safe Transportation of Detonators in a Vehicle with Certain Other Explosive Materials**

#### **FOREWORD**

When transporting explosive materials, it is often desirable to carry detonators on the same motor vehicle with other explosive materials. Tests conducted by the IME, and witnessed by the Department of Transportation (DOT), have demonstrated that under specific conditions, certain detonators can be transported with other explosive materials on the same vehicle. DOT regulations prohibit the transport of detonators with explosives unless certain specific requirements are met.<sup>1</sup>

Since 1972, DOT has accepted this publication, *Recommendations for the Safe Transportation of Detonators in a Vehicle with Certain Other Explosive Materials*, SLP-22 as one of these specific requirements. SLP-22 is adopted by reference by DOT at 49 CFR 177.835(g)(3)(ii). SLP-22 has remained virtually unchanged since 1972 and has proven an extremely effective standard. None of millions of shipments of detonators and explosives made using SLP-22 have resulted in a mass-detonation.

Notwithstanding, the primary intent of SLP-22 is not to prevent mass detonation, but instead to allow sufficient time in the event of a transportation incident such as fire to evacuate bystanders to a safe distance. Testing has shown that transporting detonators in an undamaged box constructed to the standard set forth in this SLP will prevent, for 30 minutes or more, mass detonation.

Research has shown that several modifications to SLP-22 boxes will improve their performance in fire incidents.<sup>2</sup> These modifications have been included in this edition of SLP-22. Containers and compartments manufactured after February 2007 should be made to this updated standard. Containers and compartments in service before February 2007 are permitted indefinitely provided they meet the May 1993 edition of SLP-22.

The 2007 edition of SLP-22 improved the standard's clarity and incorporated four technical modifications. The first modification was to no longer require 1/2 inch of play in the door opening. IME determined that this pressure release requirement is not necessary for safe and secure transportation. Overpressure from the functioning of a detonator cannot be significantly relieved by a small gap around one edge of the door of an SLP-22 box. Additionally, a tightly closed SLP-22 box will generally provide better security against unauthorized access and decreases the likelihood that a detonator will be thrown from the box in a fire.

The second modification required that door latches be securely padlocked. Testing has shown that this is necessary to prevent premature opening of the door and ejection of live detonators. Security from unauthorized access is also enhanced by this provision.

---

<sup>1</sup> Title 49 Code of Federal Regulations (49 CFR) Part 177.835(g).

<sup>2</sup> Santis, Lon. "Fire Protection Provided by Detonator Containers" 23rd Annual Conference on Explosives and Blasting Techniques, Las Vegas, NV, (February 2-5, 1997).

The other two modifications improved the survivability of the container or compartment in a fire. Since aluminum, plastic, and rubber melt at temperatures well below those commonly encountered in vehicle fires, steel is required for critical structural hardware such as hinges and latches. Also, this hardware must be attached to the metal shell of the container or compartment. Hardware attached to only the outer layer of plywood provides little integrity once the wood burns away.

Modifications to the current edition of SLP-22, among other things, include provisions addressing; (i) positioning the box on the vehicle at a location removed from high temperature areas (SLP-22 Specifications at C.1.a), (ii) a requirement that SLP-22 containers mounted on cargo tank motor vehicles comply with IME SLP-23 (SLP-22 Specifications at C.1.c), (iii) alternative materials for construction of the SLP-22 Box (SLP-22 Specifications at C.4.9), and (iv) a clarifying revision of Appendix A, Explosives Transportation Classifications.





## **BACKGROUND**

DOT has essentially adopted the United Nations' explosives classification system as described in the *Recommendations on the Transport of Dangerous Goods, Model Regulations, ST/SG/AC.10/1*. Explosives are Class 1 materials and assigned a division number, indicative of the particular transport hazard of the material, and a compatibility group letter, indicative of what materials can be transported together without significantly increasing the probability or the magnitude of a transportation accident.

Explosive blasting materials such as dynamite, cast boosters, and other commonly used detonator-sensitive explosives are classified as 1.1D (Class 1, Division 1, Compatibility Group D). Blasting Agents (such as ANFO and non-detonator-sensitive emulsions, slurries, and water gels), are classified as 1.5D (Class 1, Division 5, Compatibility Group D).

Detonators that present a mass-detonation hazard are classified as 1.1B (Class 1, Division 1, Compatibility Group B).

Detonators that should not mass detonate are classified as 1.4B or 1.4S (Class 1, Division 4, Compatibility Group B or S).

See Appendix A for more information about explosives transportation classifications.

## **COMPATIBILITY OF CLASS 1 MATERIALS**

Generally, packages with different compatibility group letters should not be transported together on the same motor vehicle. For example, 1.1B, 1.2B and 1.4B materials can be transported on the same motor vehicle since they all have the same compatibility letter (B). Likewise 1.1D, 1.2D, 1.4D and 1.5D materials can be transported together on the same motor vehicle. But 1.1B and 1.1D materials should not be transported on the same motor vehicle. There are a few exceptions to this general rule. For example, compatibility groups C, D, and E can be shipped together.

Another major exception is that 1.4B, 1.4S, and certain 1.1B detonators may be transported safely on the same motor vehicle with explosives in other compatibility groups provided the detonators are shipped in accordance with SLP-22. Only 1.1B detonators containing no more than one gram of explosives (excluding ignition and delay charges), and electric detonators with leg wires four feet (ft) [1.25 meters (m)] or longer, may be transported on the same motor vehicle with explosives. These types of 1.1B detonators are non-mass detonating regardless of their packaging.

As shown in Table 1, DOT permits the shipment of detonators 1.4B and 1.4S and certain 1.1B detonators on the same motor vehicle with other Class 1 materials when the detonators are shipped in accordance with SLP-22 specifications.

**TABLE 1**  
**Compatibility Table for Class 1 Commercial Blasting Materials.<sup>3</sup>**

<b>Compatibility Group</b>	<b>A</b>	<b>B</b>	<b>C</b>	<b>D</b>	<b>E</b>	<b>G</b>	<b>S</b>
A	-	No	No	No	No	No	No
B	No	-	No	No <sup>4</sup>	No	No	Yes <sup>4,5</sup>
C	No	No	-	Yes	Yes	Yes <sup>6</sup>	Yes <sup>4,5</sup>
D	No	No <sup>4</sup>	Yes	-	Yes	Yes <sup>6</sup>	Yes <sup>4,5</sup>
E	No	No	Yes	Yes	-	Yes <sup>6</sup>	Yes <sup>4,5</sup>
G	No	No	Yes <sup>6</sup>	Yes <sup>6</sup>	Yes <sup>6</sup>	-	Yes <sup>4,5</sup>
S	No	Yes	Yes <sup>4,5</sup>	Yes <sup>4,5</sup>	Yes <sup>4,5</sup>	Yes <sup>4,5</sup>	-

**SLP-22 SPECIFICATIONS**

**A. Applicable Products**

1. Class 1 materials that may be transported together on the same motor vehicle are limited to:
  - a. Detonators, electric, 1.4B, UN 0255;
  - b. Detonators, electric, 1.4S, UN 0456;
  - c. Detonators, non-electric, 1.4B, UN 0267;
  - d. Detonators, non-electric, 1.4S, UN 0455;
  - e. Detonator assemblies, non-electric 1.4B, UN 0361;
  - f. Detonator assemblies, non-electric 1.4S, UN 0500; or
  - g. Detonators, electric, 1.1B UN 0030 that contain no more than one (1) gram of explosive (excluding ignition and delay charges) and with leg wires four ft (1.25 m) or longer.

-AND-

Explosive materials in other compatibility groups, as described in Table 1 above and 49 CFR 177.848.

**B. Packaging, Labeling, Marking, and Loading**

1. Detonators shall be packaged and loaded on a motor vehicle in accordance with Table 2. Inner packaging is not required for electric detonators that are packed inside pasteboard tubes, or wound on spools with the detonator placed inside the spool, so as to restrict freedom of movement of the detonator and protect them from impact forces.

<sup>3</sup> 49 CFR 177.848 (f).

<sup>4</sup> Allowed if SLP-22 or other DOT criteria at 49 CFR 177.835(g) are met.

<sup>5</sup> Division 1.4S fireworks may not be loaded on the same motor vehicle with Division 1.1 or 1.2 materials.

<sup>6</sup> Explosive articles in compatibility group G, other than fireworks and those requiring special handling, may be loaded, transported and stored with other explosive articles of compatibility groups C, D and E, provided that explosive substances (such as those not contained in articles) are not carried in the same vehicle.

**TABLE 2**  
**Generic loading and packaging guide**

Proper Shipping Name	Division	UN #	Quantity Limitation	Minimum Packaging Requirements	Comments
Detonators, electric	1.1B	UN 0030	None	Original shipping case <sup>7</sup>	Leg wires must be 4 ft (1.25 m) or longer. Maximum base charge 1 gram of explosives.
Detonators, electric	1.1B	UN 0030	1,000	Carton <sup>8</sup>	Leg wires must be 4 ft (1.25 m) or longer. Maximum base charge 1 gram of explosives. Carton cannot contain more than 50 detonators.
Detonator assemblies, non-electric	1.4B	UN 0361	None	Original shipping case <sup>7</sup>	
Detonator assemblies, non-electric	1.4S	UN 0500			
Detonators, electric	1.4B	UN 0255			
Detonators, electric	1.4S	UN 0456			
Detonators, non-electric	1.4B	UN 0267			
Detonators, non-electric	1.4S	UN 0455			
Detonator assemblies, non-electric	1.4B	UN 0361			
Detonator assemblies, non-electric	1.4S	UN 0500			
Detonators, electric	1.4B	UN 0255			
Detonators, electric	1.4S	UN 0456			
Detonators, non-electric	1.4B	UN 0267			
Detonators, non-electric	1.4S	UN 0455			

2. No material may be loaded on top of a portable SLP-22 container which contains Class 1 materials, nor is any material to be loaded against the outside of the door of an SLP-22 compartment.
3. When Class 1 materials are loaded in a portable SLP-22 container, the warning: "**CONTAINS EXPLOSIVES, HANDLE CAREFULLY**" must be displayed on the outside of the container's lid in letters at least 1/2 inch high. Labeling and marking of the SLP-22 container or compartment containing detonators is not required when the compartment is an integral part of the vehicle body or the container is permanently attached to the motor vehicle.

<sup>7</sup> Outer and inner packaging authorized by DOT.

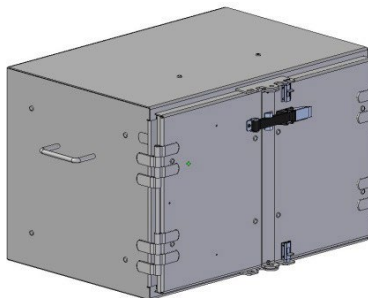
<sup>8</sup> Inner packaging, if any, authorized by DOT.

This applies even when the detonators are in inner packaging only, as authorized in Table 2 above, and the motor vehicle contains any quantity of Class 1 materials and is placarded accordingly.

4. The container or compartment must be secured with a padlock(s) to prevent unauthorized entry.
5. Shipments of Class 1 materials in different divisions must be placarded with the lowest placardable division number of the cargo load. For example, when transporting Division 1.1 explosives with Division 1.4 detonators, the motor vehicle must be placarded Division 1.1.
6. In general, the lowest division's compatibility group is used but see 49 CFR 173.61 and 177.848 for complete information on use of the proper compatibility group with mixed shipments.
7. An SLP-22 container that is not permanently attached to the motor vehicle and used as an outer packaging or overpack must be marked and labeled in accordance with 49 CFR 172 Subparts D and E.
8. In the combined transportation of detonators and other Class 1 explosive materials, either the detonators or the other Class 1 explosive materials may be transported in the SLP-22 container or compartment.

### C. Construction

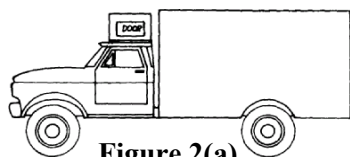
1. SLP-22 containers and compartments shall be incorporated into the motor vehicle in one of the following manners. Positions of the container or compartment in the figures are examples only. Other positions may be acceptable based on the vehicle cargo space configuration.
  - a. In choosing positions for the SLP-22 Container, the user should consider options that remove the SLP-22 container as far as possible from the points on the vehicle that are most susceptible to high temperature fires due to accidents or severe mechanical failures. The fuel tanks and tires of the vehicle normally provide the greatest risk of high temperature fires.
  - b. A portable SLP-22 container, as shown in Figure 1, must be placed within (and be readily removable from) the cargo-carrying space of the vehicle, or provide direct access to the SLP-22 container from outside the vehicle.



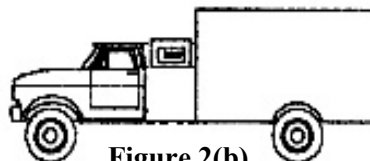
**Figure 1. Portable SLP-22 Container**

<sup>9</sup> ASTM 883-97 Standard Performance Specification for Padlocks, Jan 10, 1997.

- c. An SLP-22 container securely attached to the motor vehicle above or behind the cab of the motor vehicle as shown in Figures 2(a) and (b) or under the cargo space as shown in Figures 3(a) and (b).

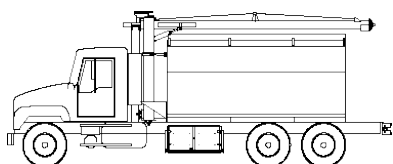


**Figure 2(a)**

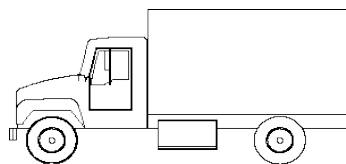


**Figure 2(b)**

**Examples of an SLP-22 container mounted above and behind the motor vehicle cab.**



**Figure 3(a)**

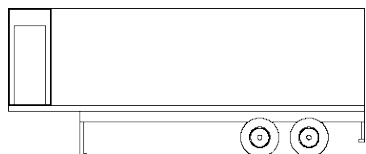


**Figure 3(b)**

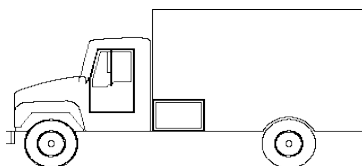
**Examples of SLP-22 containers mounted under the cargo space of a motor vehicle.**

The configurations shown in Figure 3(a) and (b) are equally applicable to multi-axle and “cab-over” vehicles. In the case of an SLP-22 container mounted on a Cargo Tank Motor Vehicle, the mounting configuration must satisfy the requirements of IME SLP-23.

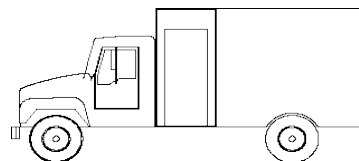
- d. A built-in compartment in the cargo space of the vehicle as shown in Figures 4(a), (b), and (c).



**Figure 4(a)**



**Figure 4(c)**



**Figure 4(b)**

**Examples of SLP-22 compartments built into the cargo space of a motor vehicle.**

- 2. The SLP-22 container or compartment must provide for total enclosure of the contents with no contact with or exposure to any other materials loaded in the cargo compartments.

3. The exterior walls and lid or door of each SLP-22 container or compartment shall consist of a laminate constructed of not less than 11 gauge steel, continuously welded at all joints, and lined with 1/2 inch sheetrock and 1/2 inch A/C grade or better exterior plywood as shown in Figure 5.

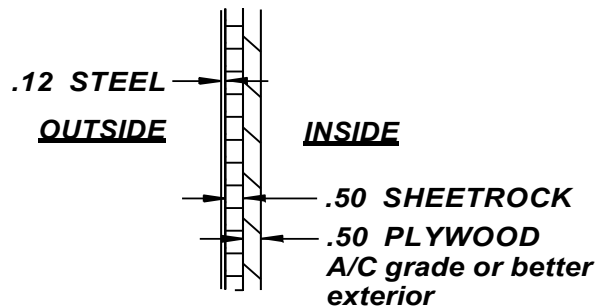


Figure 5. SLP-22 wall laminate shown with steel outer covering.

4. The exterior portion of a container or compartment must be covered with a minimum thickness 1/4 inch lamination of A/C grade or better exterior plywood as shown in Figure 6 only if other explosives carried on the vehicle contact the exterior of the SLP-22 Box.

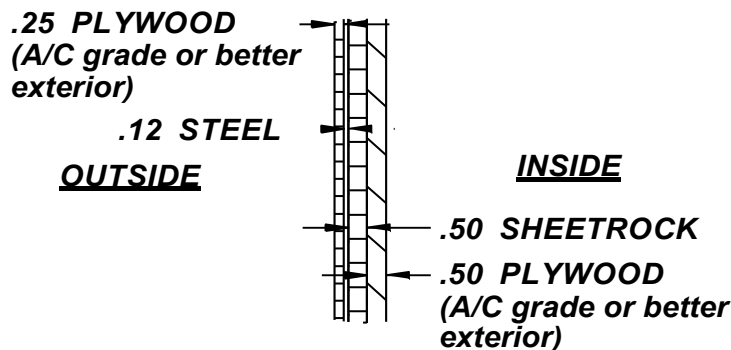


Figure 6. SLP-22 wall laminate shown with plywood outer covering for use when other explosives carried on the vehicle contact the exterior of the SLP-22 Box.

5. The laminated materials must be securely bound together by water-proof adhesive or other equally effective means.
6. The steel at the joints of lamination must be secured by continuous fillet welds.
7. Latches, hinges, and other structural components must be made of steel.
8. Latches, hinges, and other structural components must be attached by bolting or welding to the steel in the wall laminate so they cannot be easily removed.
9. Alternative materials may be used to construct the SLP-22 Box only when they achieve the following performance characteristics:
  - a. The inside layer must be constructed of or covered with non-sparking material. For containers that are in use where other explosives can contact the exterior (figure 6) the outside layer must also be constructed of or covered with non-sparking material.

- b. The alternate materials must have a combined thermal conductivity for the composite wall that is equal to or less than the combined thermal conductivity of standard wall construction using the following formula

$$k_c = (k_1 * k_2 * k_n * \dots) / (L_1 * k_1 + L_2 * k_2 + L_n * k_n + \dots)$$

where  $k_c$  = composite thermal conductivity  
 $k_1$  = thermal conductivity layer 1  
 $k_n$  = thermal conductivity layer n  
 $L_1$  = thickness layer 1  
 $L_n$  = thickness layer n

For standard wall construction the combined thermal conductivity is

$$k_c = (.17 * .13) / (.5 * .17 + .5 * .13) = .1473 \text{ W/m}$$

Suitable materials for the laminate construction include (but are not limited to) those listed in the following table.

Material	W/m*K	Btu/Ft*hr*F
1 <sup>st</sup> layer		
Gypsum Board	.17	.0982
Ceramic fiber board	.085	.0491
Mineral wool board	.052	.0300
Magnesium Oxide (Mgo) Board	.15	.0867
Firex Board-II™	.089	.0154
2 <sup>nd</sup> layer (interior)		
Plywood	.13	.0751
Firex Board-II™	.089	.0154
Mgo Board	.15	.0867

- c. The alternate materials must have a higher autoignition temperature than the autoignition temperature for the standard materials.
- d. The alternate materials must be able to withstand normal transport operating and climate conditions without degradation of the material or its insulating properties.
10. There must be direct access to the SLP-22 container or into an SLP-22 compartment from outside the vehicle. SLP-22 containers should never be opened inside the cargo compartment of the vehicle if the vehicle contains any other products of any kind.
11. Each SLP-22 container or compartment must have a snug-fitting lid or door and be equipped with a means to provide for locking.
12. The exterior of the SLP-22 container or compartment must be weather-resistant.
13. Portable SLP-22 containers shall be secured to the motor vehicle to prevent movement during transport.

**D. Identification**

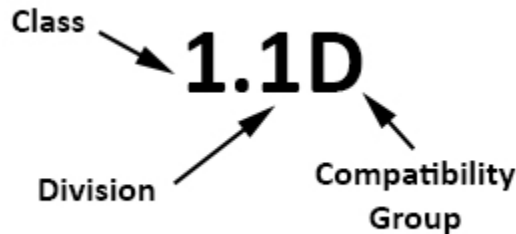
The interior surface of the lid or door of an SLP-22 container or compartment must be marked in letters and numbers at least 1/2 inch high as follows:

**BARRIER LAMINATE  
MEETS SLP #22**



## APPENDIX A EXPLOSIVES TRANSPORTATION CLASSIFICATIONS

DOT utilizes the United Nations classification system, consisting of two numbers and a letter to describe explosives according to *Class*, *Division*, and *Compatibility Group* (see figure).



The significance of Class, Division, and Compatibility Group are noted below.

Class	<p>A hazardous material is assigned a class number to indicate its transport hazard. Explosive substances and articles are in Class 1. There are 8 other classes identifying other hazard classes such as corrosives, flammables, oxidizers, compressed gases, poisons, etc.</p> <p>See 49 CFR 173.2 for more information.</p>
Division	<p>Class 1 materials are subdivided into six divisions signifying the primary hazard:</p> <ul style="list-style-type: none"> <li>• 1.1 mass explosion</li> <li>• 1.2 projections</li> <li>• 1.3 fire</li> <li>• 1.4 minor hazard</li> <li>• 1.5 mass explosion but very insensitive</li> <li>• 1.6 very insensitive articles.</li> </ul> <p>See 49 CFR 173.50 for more information.</p>
Compatibility Group Letter	<p>Explosives are assigned a compatibility group letter to indicate their compatibility with other explosives. Generally, only explosives with the same compatibility group letter can be transported together. Detonators 1.4B or 1.4S and certain detonators 1.1B may be shipped with certain other Division 1.1D materials in accordance with SLP-22 specifications.</p> <p>See 49 CFR 173.52 for a description of the thirteen explosives compatibility groups.</p>

*Note: as used here, Class 1 materials are considered to be compatible if they can be safely transported together without significantly increasing either the probability of an accident or, for a given quantity, the magnitude of the effect of such an accident.*

## Safety Library Publications

<b>SLP Number</b>	<b>SLP Name</b>	<b>Copyright Date</b>
SLP – 1	Construction Guide for Storage Magazines	October 2017 (Includes changes through January 2022)
SLP – 2	American Table of Distances	June 1991 (Incorporates changes through April 2017)
SLP – 3	Suggested Code of Regulations for the Manufacture, Transportation, Storage, Sale, Possession and Use of Explosive Materials	February 2021
SLP – 4	Warning and Instructions for Consumers in Transporting, Storing, Handling and Using Explosive Materials	December 2022
SLP – 12	Glossary of Commercial Explosives Industry Terms	March 2018
SLP – 14	Handbook for the Transportation and Distribution of Explosive Materials	March 2019
SLP – 17	Safety in the Transportation, Storage, Handling and Use of Explosive Materials	June 2021
SLP – 20	Safety Guide for the Prevention of Radio Frequency Radiation Hazards in the Use of Commercial Electric Detonators (Blasting Caps)	December 2011
SLP – 22	Recommendations for the Safe Transportation of Detonators in a Vehicle with Certain Other Explosive Materials	October 2019
SLP – 23	Recommendations for the Transportation of Explosives, Division 1.5, Ammonium Nitrate Emulsions, Division 5.1, Combustible Liquids, Class 3, and Corrosives, Class 8 in Bulk Packaging	March 2021
SLP – 24	Recommendations for Handling Explosives at Designated Waterfront Facilities in the United States	May 2022
SLP – 25	Explosives Manufacturing & Processing Guideline to Safety Training	October 2018
SLP – 27	Security in Manufacturing, Transportation, Storage and Use of Commercial Explosives	March 2019
SLP – 28	Recommendations for Accountability and Security of Bulk Explosives and Bulk Security Sensitive Materials	September 2020
SLP – 29	Recommendations for the Environmental Management of Commercial Explosives	November 2023
SLP – 30	Safe Handling of Solid Ammonium Nitrate	April 2017
SLP – 31	Methods and Algorithms Used for Quantitative Risk Analysis	June 2018 (Includes July 2020 Amendments)
SLP 32	Recommendations for Safe and Secure Use, Storage, and Transportation of Commercial Explosives in Oil and Gas Operations	October 2018

## **DESTRUCTION OF COMMERCIAL EXPLOSIVE MATERIALS**

At times it may be necessary to destroy commercial explosive materials. These may consist of explosives or blasting agents from containers that have been broken during transportation or may be materials that have exceeded their recommended shelf life or are believed to be overage or are no longer needed.

Due to the many developments in explosive technology over the past few years, the appearance and characteristics of products have undergone marked changes. To be sure that you are familiar with the properties of the product that you plan to destroy, the manufacturer of that product should be consulted for the most current product information and the recommended method of disposal and/or destruction.

The member companies of the Institute of Makers of Explosives have agreed to supply advice and assistance in destroying explosives. If the manufacturer is known, seek his assistance. If the manufacturer is not known, a member company of the Institute of Makers of Explosives may provide advice or assistance.

The above policy of IME member companies relates only to commercial explosive materials. It does not include handling improvised explosive devices or bombs, military ordnance, military explosives, or homemade explosive materials.

IME member companies also cannot become involved in destroying explosive materials, which have been used for illegal purposes, are reportedly stolen property or are considered as evidence in any potential civil litigation or criminal prosecution.



# IME

institute of makers of explosives

Washington, DC  
Tel 202/429-9280  
[www.ime.org](http://www.ime.org)  
[info@ime.org](mailto:info@ime.org)

*Printed in the USA*